

# RC2 & RC3 CON FERRAMENTA AK PLUS

Ferramenta anti effrazione per cava K  
*Anti Burglar Hardware for K Groove*

- › Manuale di lavorazioni e assemblaggio  
*Machinings & assembling manual*



## REVISIONI / UPDATES

La tabella sotto riportata elenca le ultime modifiche apportate al catalogo.  
Eventuali aggiornamenti saranno pubblicati sul sito web.

**Scansiona o clicca il QR code** per consultare l'ultima versione.

*The below index show the latest revisions.*

*Any updates will be published on the website.*

**Scan or click the QR code** to download the latest version.



ULTIMA REVISIONE  
LATEST UPDATE

VERSIONE VERSION	REVISIONE REVISION	DATA DATE	DESCRIZIONE DESCRIPTION	PAGINA PAGE
1	A	14.02.2025	Prima emissione <i>First issue</i>	Intero manuale <i>Complete manual</i>
2	A	20.04.2026	Revisione generale e introduzione della RC3 <i>General review with RC3 implement</i>	Intero manuale <i>Complete manual</i>

## INDICE

DESCRIZIONE DESCRIPTION	PAGINA PAGE
Specifiche tecniche <i>Specification</i>	1.01
Schemi applicativi <i>Application schemes</i>	2.01
Schemi ferramenta <i>Hardware diagram</i>	3.01
Taglio aste <i>Rods cutting lists</i>	4.01
Lavorazioni varie <i>Other machinings</i>	5.01
Schemi di fissaggio dei telai <i>Structure fixing diagram</i>	6.01

**PER GLI ACCESSORI DI SISTEMA, RIFERIRSI AI CATALOGHI TECNICI DELLE SERIE UTILIZZATE  
FOR SYSTEM ACCESSORIES, REFER TO THE TECHNICAL CATALOGS OF THE SERIES USED**

Le informazioni contenute in questi disegni sono di proprietà intellettuale esclusiva di AluK S.A.  
Possono essere utilizzate al solo scopo per cui sono state fornite e non devono essere riprodotte, memorizzate o diffuse a terzi in qualsiasi modo o forma senza il permesso scritto di AluK S.A.

La politica AluK S.A. di miglioramento continuo determina il diritto di apportare modifiche senza preavviso.

*Information contained in this drawing is the exclusive intellectual property of AluK S.A.*

*It may only be used for the purpose to which is has been supplied and must not be reproduced, stored or disseminated to third parties in any way or form without the prior written permissions of AluK S.A.*

*The AluK S.A. policy of continuous improvement determines the right to make the modifications without prior warning.*



## SPECIFICHE TECNICHE TECHNICAL SPECIFICATIONS

Il presente documento costituisce un'appendice del manuale di installazione della ferramenta  $\alpha K^+$  e riporta le istruzioni di montaggio dei dispositivi opzionali antieffrazione per le finestre AluK.

Il corretto montaggio delle apparecchiature, l'impiego di vetri con caratteristiche appropriate e adeguatamente sigillati ai profili, unitamente all'efficace fissaggio a muro dei telai, consente di ottenere infissi con la classe di resistenza all'effrazione riportata nei certificati di sistema.

Nella fattispecie, al momento sono realizzabili le seguenti tipologie costruttive:

Classe di resistenza: **RC 2 / 2N**

Serie/Tipologia: C67K = finestra anta/ribalta; anta-anta/ribalta;  
finestra ad anta singola; finestra a 2 ante  
C77K = finestra anta/ribalta; anta-anta/ribalta;  
finestra ad anta singola; finestra a 2 ante

Tipo di ferramenta: cerniere visibili 130 kg e 180 kg;  
cerniere nascoste 100 kg e 150 kg.

Le applicazioni su finestra a due ante necessitano di profilo di inversione (U20502 o U28502) sull'anta secondaria.

RC 2 - CERTIFICATI ANTIEFFRAZIONE		
CAMPIONE	CLASSE DI RESISTENZA EN 1627, EN 1628, EN 1629, EN 1630	LABORATORIO E No. CERTIFICATO
 L 1035 H 1535	RC 2 / 2N	24-000936-PR01 (PB-A01-05-en-01) ift Rosenheim 29.07.2024
 L 1535 H 1535	RC 2 / 2N	24-000936-PR02 (PB-A01-05-en-01) ift Rosenheim 31.07.2024

Test eseguiti su profilo C67K, estendibili a C77K per effetto dell'Expert Statement n. 24-000936-PR03 (GAS-A01-05-en-01).  
I risultati dei test sono validi per serramenti di superficie complessiva  $\pm 25\%$ , fatte salve le prescrizioni sulla distanza tra gli incontri.

Classe di resistenza: **RC 3**

Serie/Tipologia: C77K = finestra anta/ribalta; anta-anta/ribalta;  
finestra anta singola; finestra a 2 ante.  
C77K-CS = finestra ad anta singola;

Tipo di ferramenta: cerniere nascoste 100 kg e 150 kg.

Le applicazioni su finestra a due ante necessitano di profilo di inversione (U28502) sull'anta secondaria.

RC 3 - CERTIFICATI ANTIEFFRAZIONE		
CAMPIONE	CLASSE DI RESISTENZA EN 1627, EN 1628, EN 1629, EN 1630	LABORATORIO E No. CERTIFICATO
 L 1542 H 1042	RC 3	24-004325-PR01 (PB-A01-05-en-01) ift Rosenheim 29.07.2024
 L 2554 H 1042	RC 3	24-004325-PR02 (PB-A01-05-en-01) ift Rosenheim 31.07.2024

Test eseguiti su profilo C77K-CS ad un'anta e C77K due ante, estendibili a dimensioni e tipologie diverse per effetto dell'Expert Statement n. 24-004325-PR03 (GAS-A01-05-en-02).  
I risultati dei test sono validi per serramenti di superficie complessiva  $\pm 25\%$ , fatte salve le prescrizioni sulla distanza tra gli incontri.

## ► SPECIFICHE TECNICHE TECHNICAL SPECIFICATIONS

This document is an appendix to the aK<sup>+</sup> hardware installation manual and contains the assembly instructions for the optional anti-burglary devices for AluK windows.

Correct assembly of the equipment, the use of glass with appropriate characteristics and adequately sealed to the profiles, together with the effective fixing of the frames to the wall, allows for obtaining windows with the burglary resistance class reported in the system certificates.



In particular, the following construction types are currently possible:

Resistance class: **RC 2 / 2N**

Series/Type: C67K = Tilt and turn window; Turn/T&T window;  
turn-only window; double wing window,  
C77K = Tilt and turn window; Turn/T&T window;  
turn-only window; double wing window

Hardware type: visible hinges 130 kg and 180 kg;  
concealed hinges 100 kg and 150 kg.

Applications on double wing windows require a reversal profile (U20502 or U28502) on the slave sash.

RC 2 - BURGLAR RESISTANCE TEST REPORTS		
MOCK UP	RESISTANCE CLASS EN 1627, EN 1628, EN 1629, EN 1630	LAB & TEST REPORT N.
 L 1035 H 1535	RC 2 / 2N	24-000936-PR01 (PB-A01-05-en-01) ift Rosenheim 29.07.2024
 L 1535 H 1535	RC 2 / 2N	24-000936-PR02 (PB-A01-05-en-01) ift Rosenheim 31.07.2024



Test executed on C67K profile, applicable to C77K by means of Expert Statement no. 24-000936-PR03 (GAS-A01-05-en-01).  
The test results are valid for windows with an overall area of  $\pm 25\%$ , subject to the requirements on the distance between the strikers.

Resistance class: **RC 3**

Series/Type: C77K = Tilt and turn window; Turn/T&T window;  
turn-only window; double wing window  
C77K-CS = turn-only window.

Hardware type: concealed hinges 100 kg and 150 kg.

Applications on double wing windows require a reversal profile (U28502) on the slave sash.

RC 3 - BURGLAR RESISTANCE TEST REPORTS		
MOCK UP	RESISTANCE CLASS EN 1627, EN 1628, EN 1629, EN 1630	LAB & TEST REPORT N.
 L 1542 H 1042	RC 3	24-004325-PR01 (PB-A01-05-en-01) ift Rosenheim 29.07.2024
 L 2554 H 1042	RC 3	24-004325-PR02 (PB-A01-05-en-01) ift Rosenheim 31.07.2024

Test executed on C77K-CS single sash and C77K double sash, extendable to different dimensions and typologies by means of Expert Statement no. 24-004325-PR03 (GAS-A01-05-en-02).  
The test results are valid for windows with an overall area of  $\pm 25\%$ , subject to the requirements on the distance between the strikers.





IMMAGINE IMAGE	CODICE CODE	DESCRIZIONE DESCRIPTION	C67K	C77K	C77K-CS
	H48118	Meccanismo (anta/ribalta) per maniglie senza base DIN 100 <b>RC2 e RC3</b> <i>Mechanism for handle without base DIN 100 (T&amp;T)</i> U.V. 1	●	●	●
	H48119	<b>aK+</b> Cremonese incassata 22/43 mm <i>Gearbox 22/43 mm</i> U.V. 1	●	●	●
	H48120	Maniglia senza base, con chiave <b>RC2 e RC3</b> <b>mod. Rondo</b> <i>Handle without base, with key</i> U.V. 1	●	●	●
	H48121	Maniglia senza base, con chiave <b>RC2 e RC3</b> <b>mod. Quadra</b> <i>Handle without base, with key</i> U.V. 1	●	●	●
	H48781	<b>aK+</b> Chiusura di sicurezza asta <b>RC2 e RC3</b> <i>Security locking point for rod</i> U.V. 1	●	●	●
	H48790	<b>aK+</b> Chiusura di sicurezza, cava 14x18 <b>RC2 e RC3</b> <i>Security locking point, 14x18 groove</i> U.V. 1	●	●	

IMMAGINE IMAGE	CODICE CODE	DESCRIZIONE DESCRIPTION	C67K	C77K	C77K-CS
	H48954	<b>aK+</b> Kit aggiuntivo <b>RC2 e RC3</b> <i>Additional kit</i> U.V. 1	●	●	●
	H48955	<b>aK+</b> Kit seconda anta <b>RC2 e RC3</b> <i>Second sash kit</i> U.V. 1	●	●	
	H48958	<b>aK+</b> Chiusura di sicurezza, F/F 38 mm <b>RC2 e RC3</b> <i>Security locking point F/F 38 mm</i> U.V. 1	●	●	●



➤ RC2 - SCHEMI DI APPLICAZIONE DEI PUNTI DI CHIUSURA - ANTA ◦ ANTA/RIBALTA  
 RC2 - LOCKING POINTS APPLICATION DIAGRAM - T&T / TURN ONLY

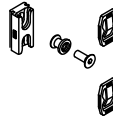
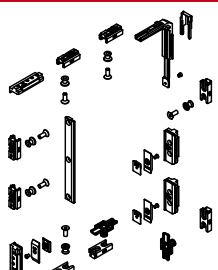
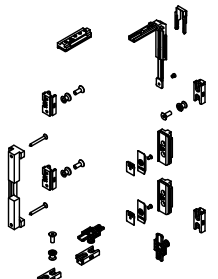
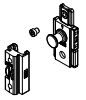
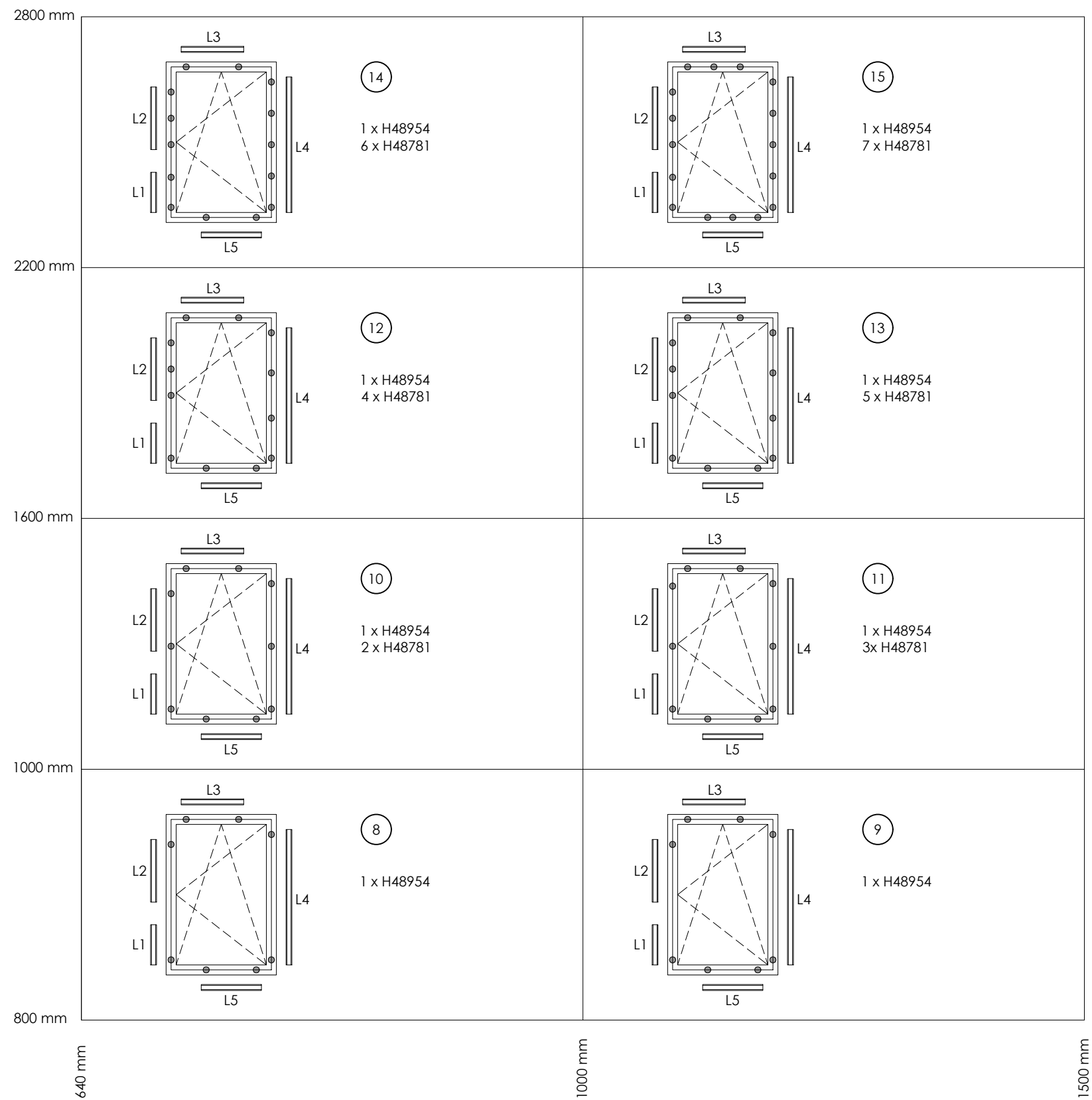

➤ RC2 - SCHEMI DI APPLICAZIONE DEI PUNTI DI CHIUSURA - ANTA SECONDARIA  
 RC2 - LOCKING POINTS APPLICATION DIAGRAM - TURN ONLY SECOND SASH

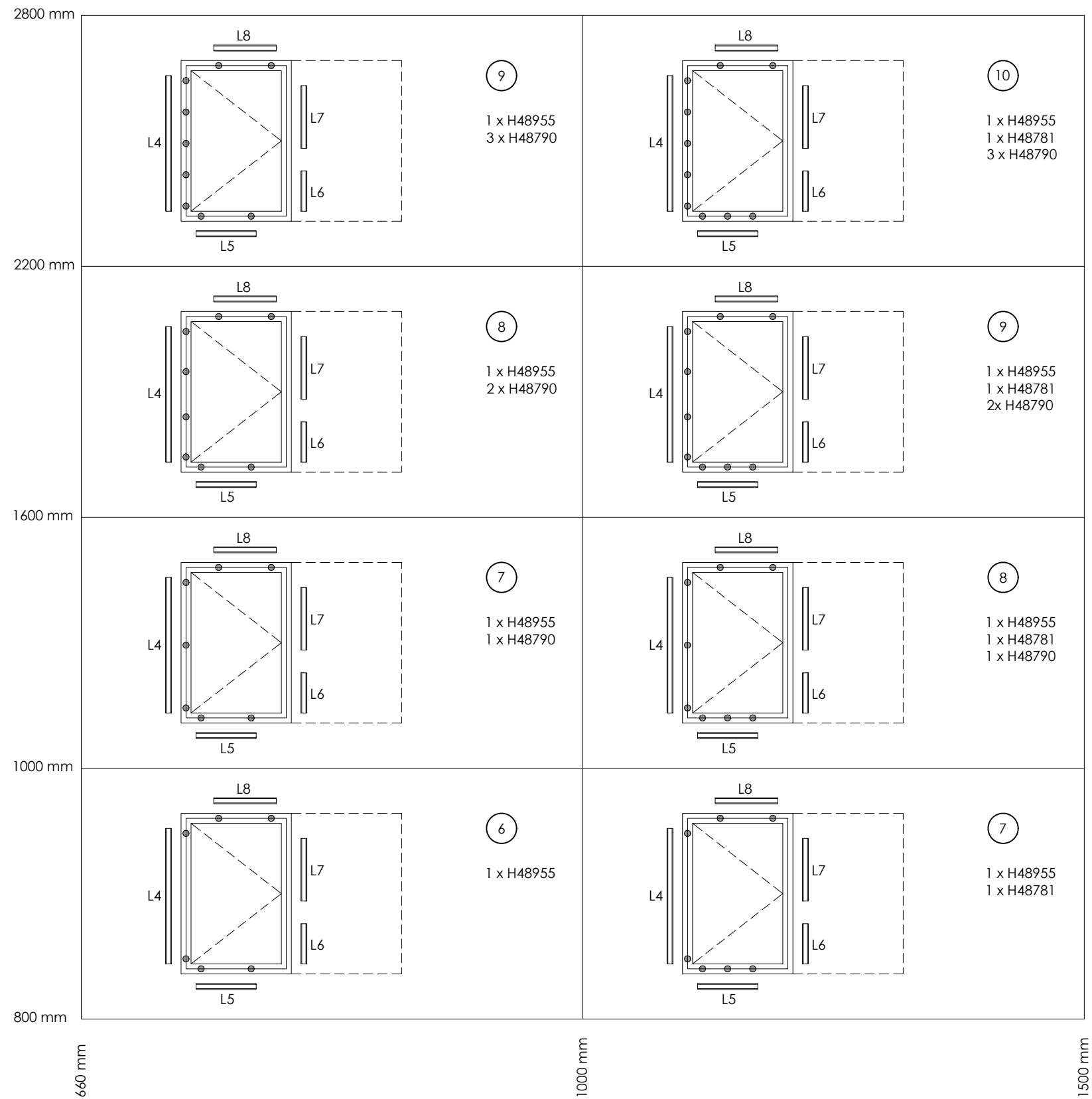

➤ RC3 - SCHEMI DI APPLICAZIONE DEI PUNTI DI CHIUSURA - ANTA ◦ ANTA/RIBALTA  
 RC3 - LOCKING POINTS APPLICATION DIAGRAM - T&T / TURN ONLY

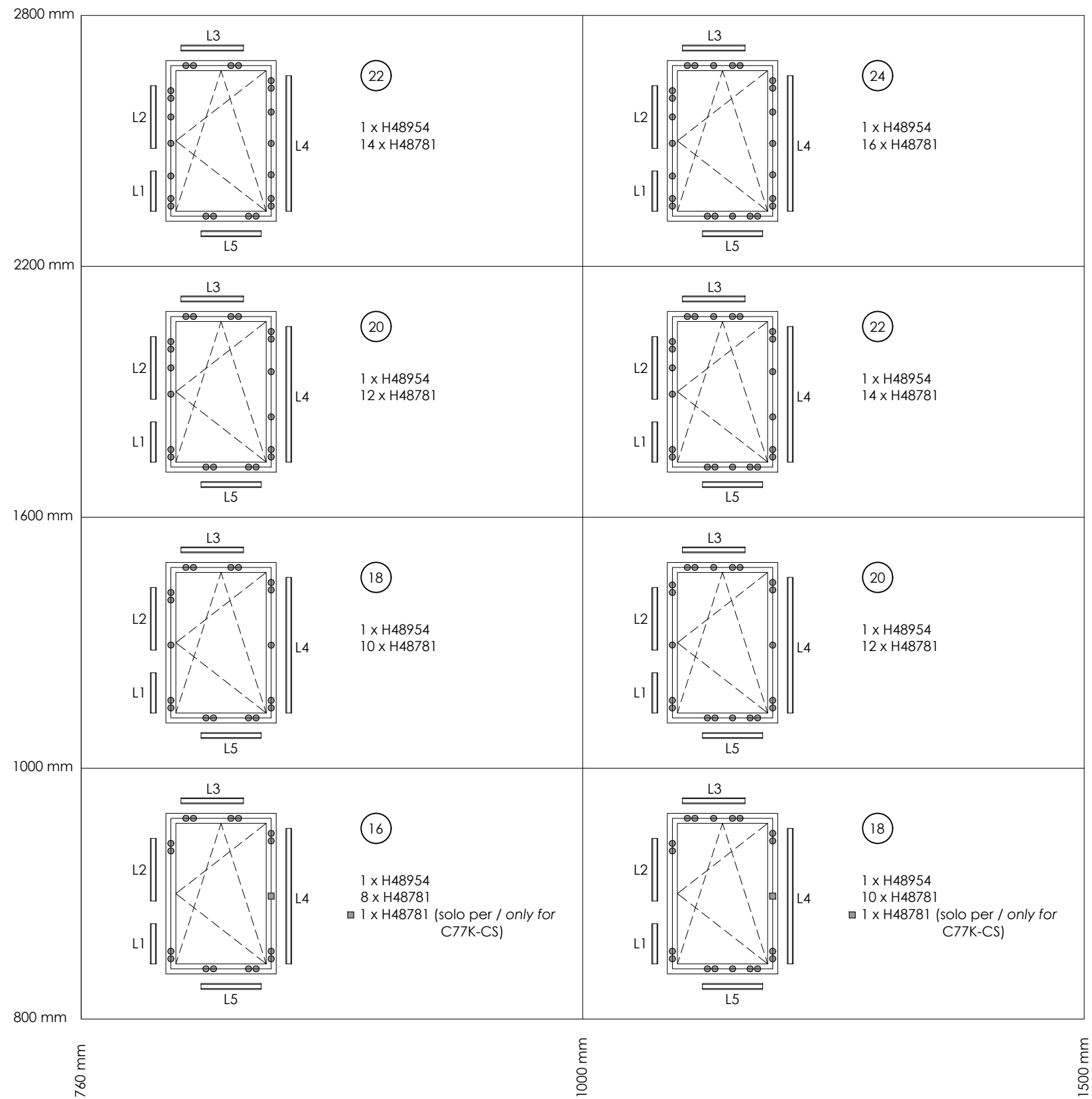

➤ RC3 - SCHEMI DI APPLICAZIONE DEI PUNTI DI CHIUSURA - ANTA SECONDARIA  
 RC3 - LOCKING POINTS APPLICATION DIAGRAM - TURN ONLY SECOND SASH

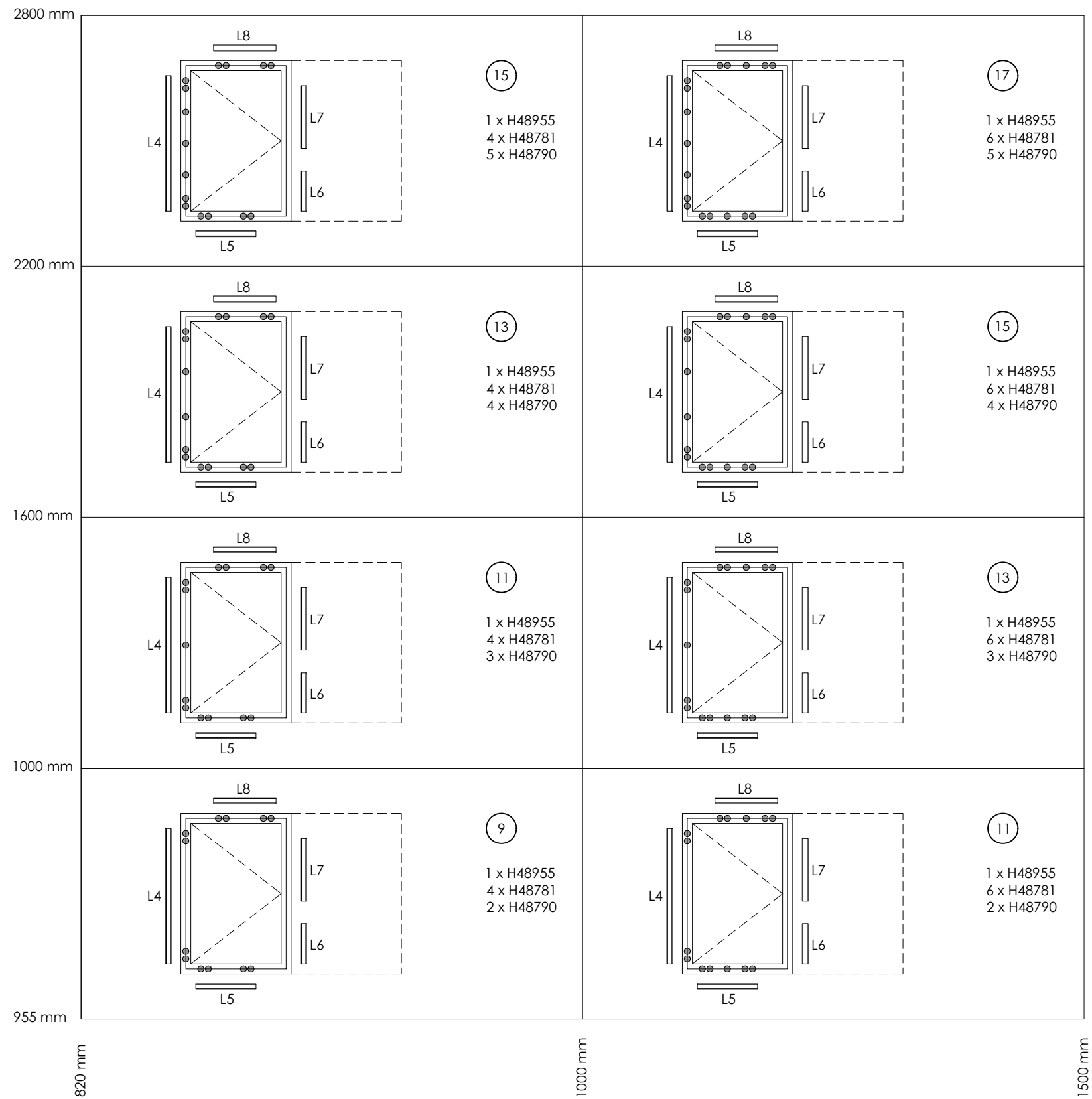

➤ RC2 - SCHEMA FERRAMENTA - FINESTRA A/R αK+ 130kg / HD 180 kg  
 RC2 - HARDWARE SCHEME - T&T WINDOWS αK+ 130 kg / HD 180 kg

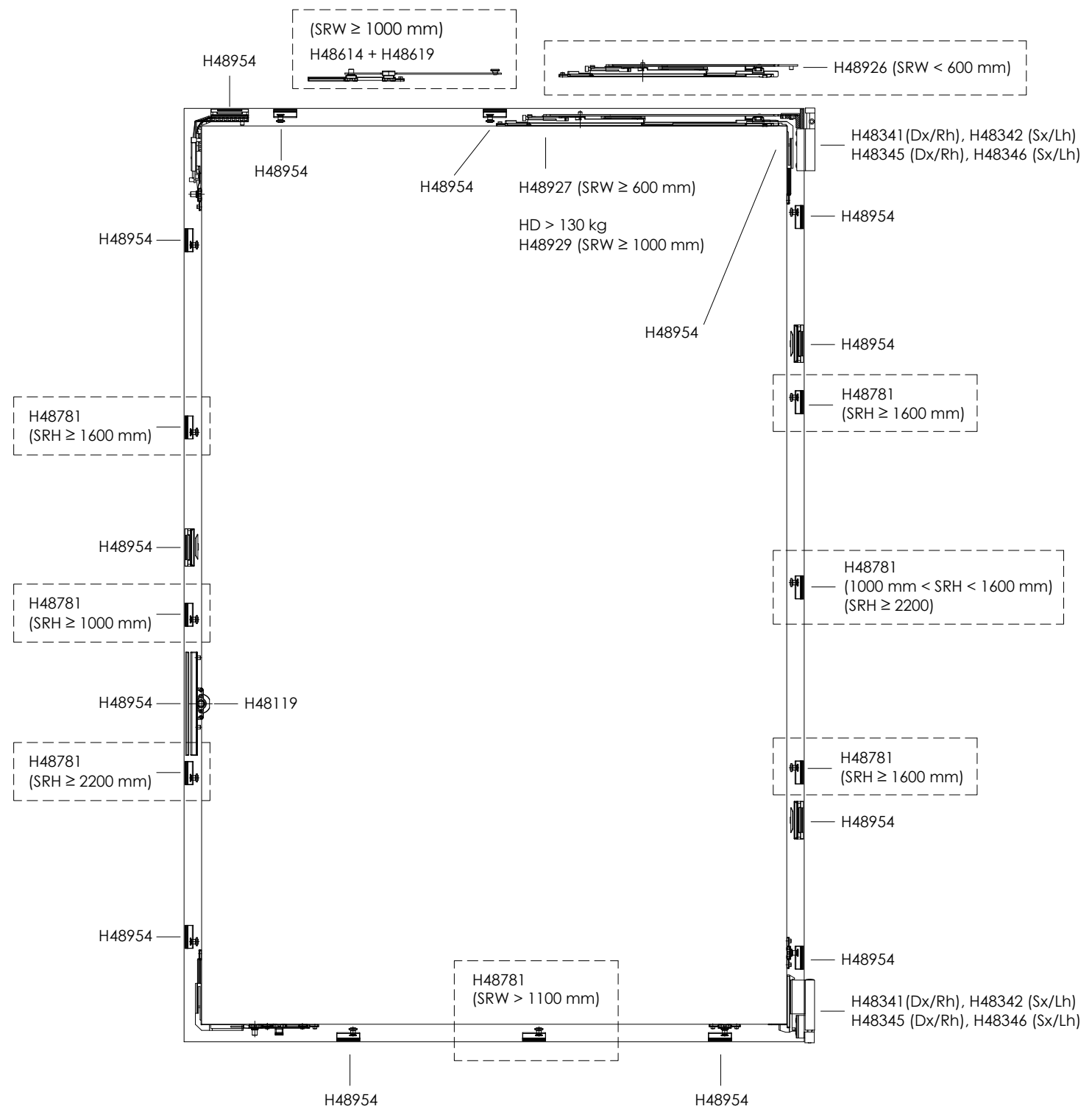
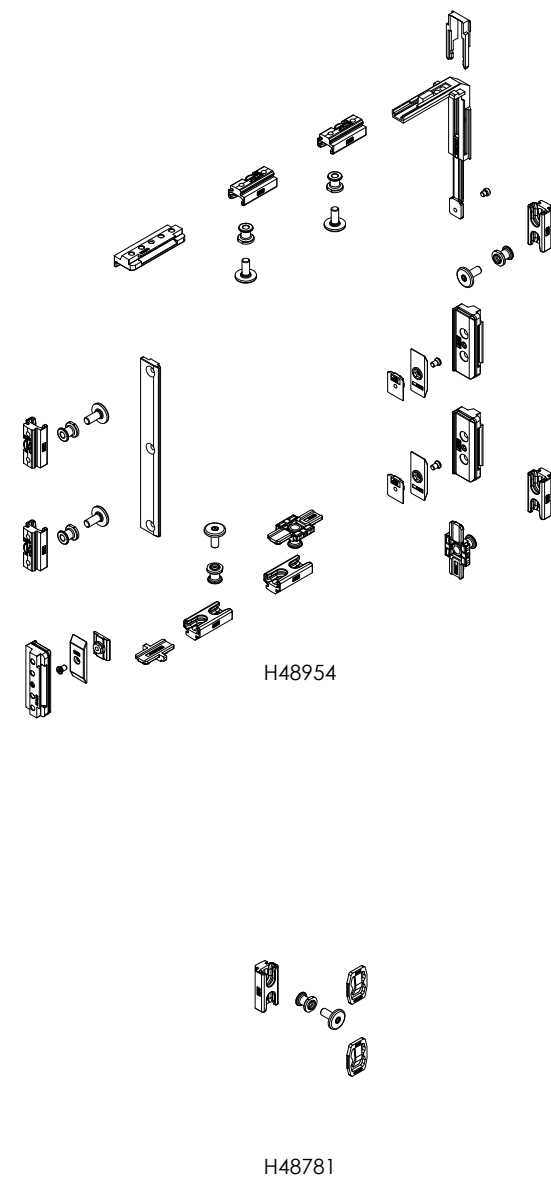







➤ RC2 - SCHEMA FERRAMENTA - FINESTRA BATTENTE aK+ 100kg / 150 kg  
 RC2 - HARDWARE SCHEME - TURN ONLY aK+ 100 kg / aK+ 150 kg

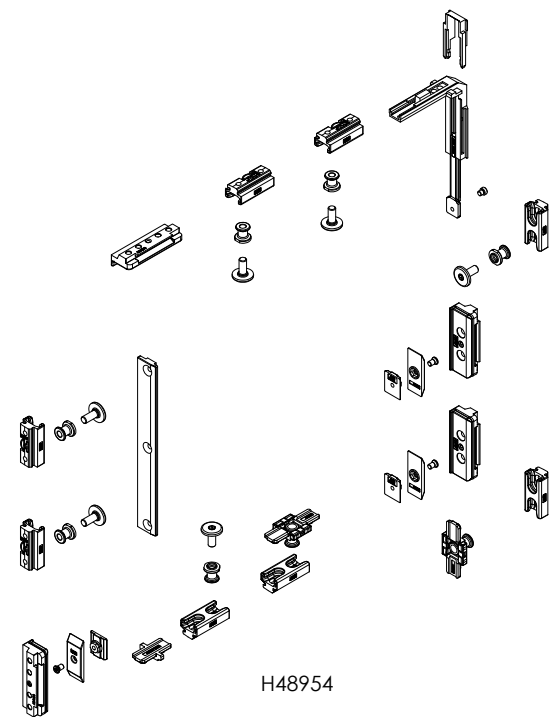

H48954

H48958

H48781

**Fino a/Up to 100 kg**  
 H48938 (Dx/Rh), H48940 (Sx/Lh)

**Da/from 100 kg a/to 150 kg**  
 H48942 (Dx/Rh), H48944 (Sx/Lh)

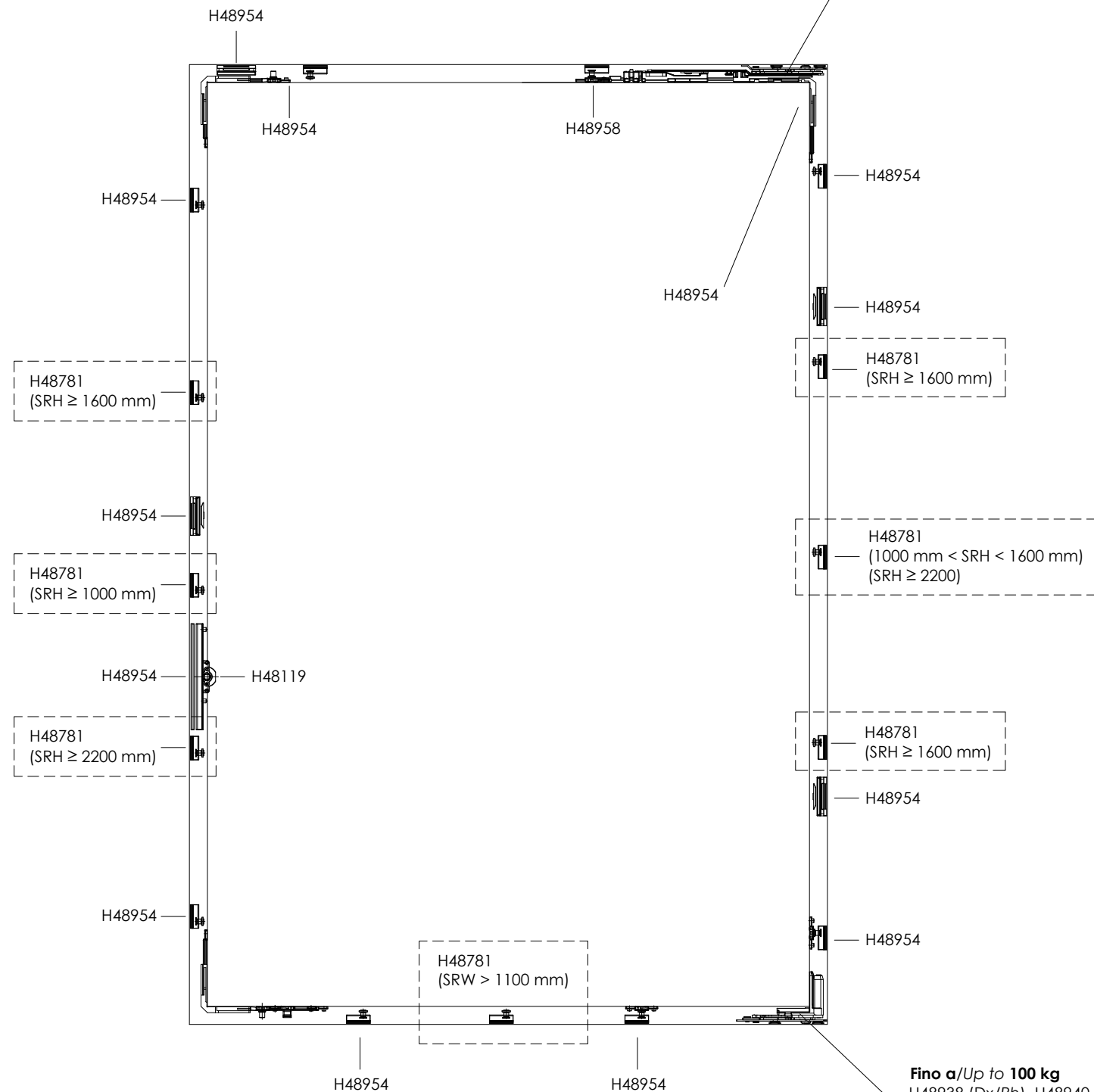

**Fino a/Up to 100 kg**  
 H48938 (Dx/Rh), H48940 (Sx/Lh)

**Da/from 100 kg a/to 150 kg**  
 H48942 (Dx/Rh), H48944 (Sx/Lh)

RC2 - SCHEMA FERRAMENTA - FINESTRA DUE ANTE aK+ 100kg / 150 kg  
 RC2 - HARDWARE SCHEME - TURN ONLY SECOND SASH aK+ 100 kg / aK+ 150 kg

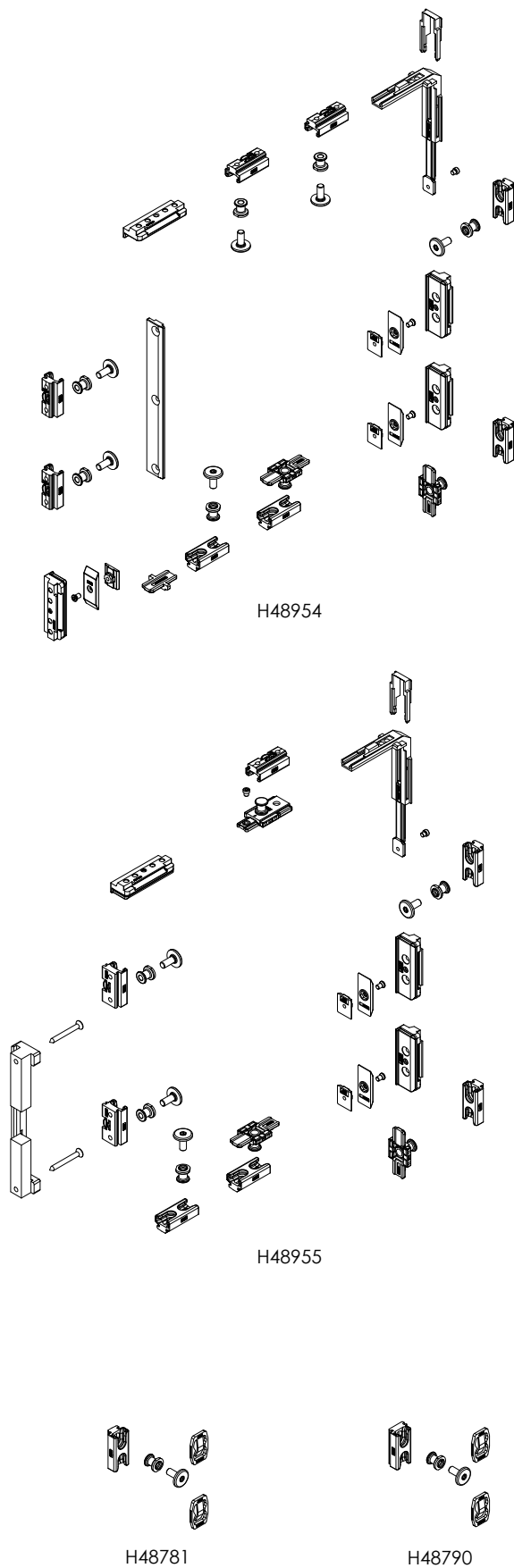

**Fino a/Up to 100 kg**  
 H48938 (Dx/Rh), H48940 (Sx/Lh)

**Da/from 100 kg a/to 150 kg**  
 H48942 (Dx/Rh), H48944 (Sx/Lh)

**Fino a/Up to 100 kg**  
 H48938 (Dx/Rh), H48940 (Sx/Lh)  
 H48939 (Dx/Rh), H48941 (Sx/Lh)

**Da/from 100 kg a/to 150 kg**  
 H48942 (Dx/Rh), H48944 (Sx/Lh)  
 H48943 (Dx/Rh), H48945 (Sx/Lh)

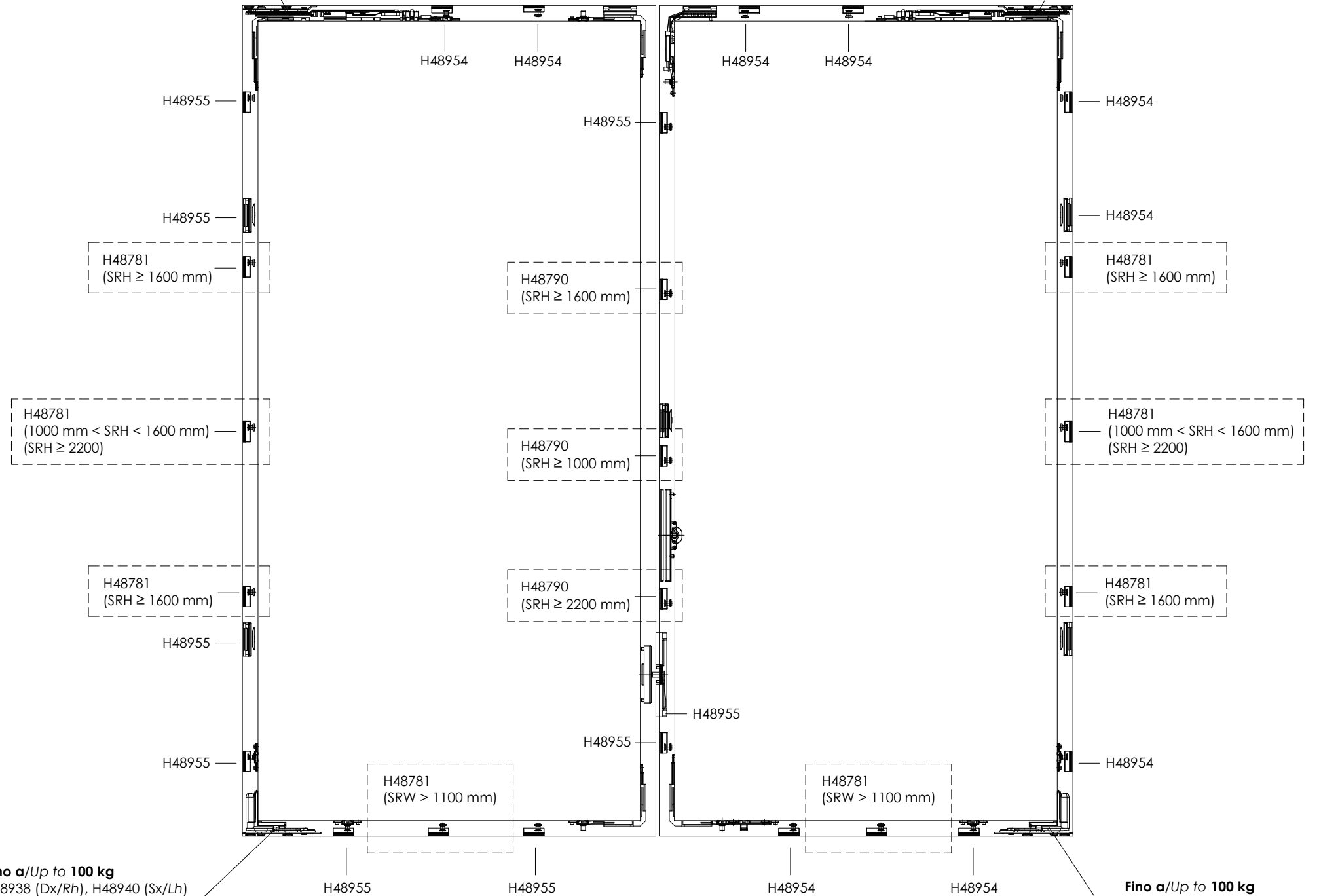

**Fino a/Up to 100 kg**  
 H48938 (Dx/Rh), H48940 (Sx/Lh)

**Da/from 100 kg a/to 150 kg**  
 H48942 (Dx/Rh), H48944 (Sx/Lh)

**Fino a/Up to 100 kg**  
 H48938 (Dx/Rh), H48940 (Sx/Lh)  
 H48939 (Dx/Rh), H48941 (Sx/Lh)

**Da/from 100 kg a/to 150 kg**  
 H48942 (Dx/Rh), H48944 (Sx/Lh)  
 H48943 (Dx/Rh), H48945 (Sx/Lh)

➤ RC3 - SCHEMA FERRAMENTA - FINESTRA A/R αK+ 100kg / 150 kg  
 RC3 - HARDWARE SCHEME - T&T WINDOWS αK+ 100 kg / αK+ 150 kg

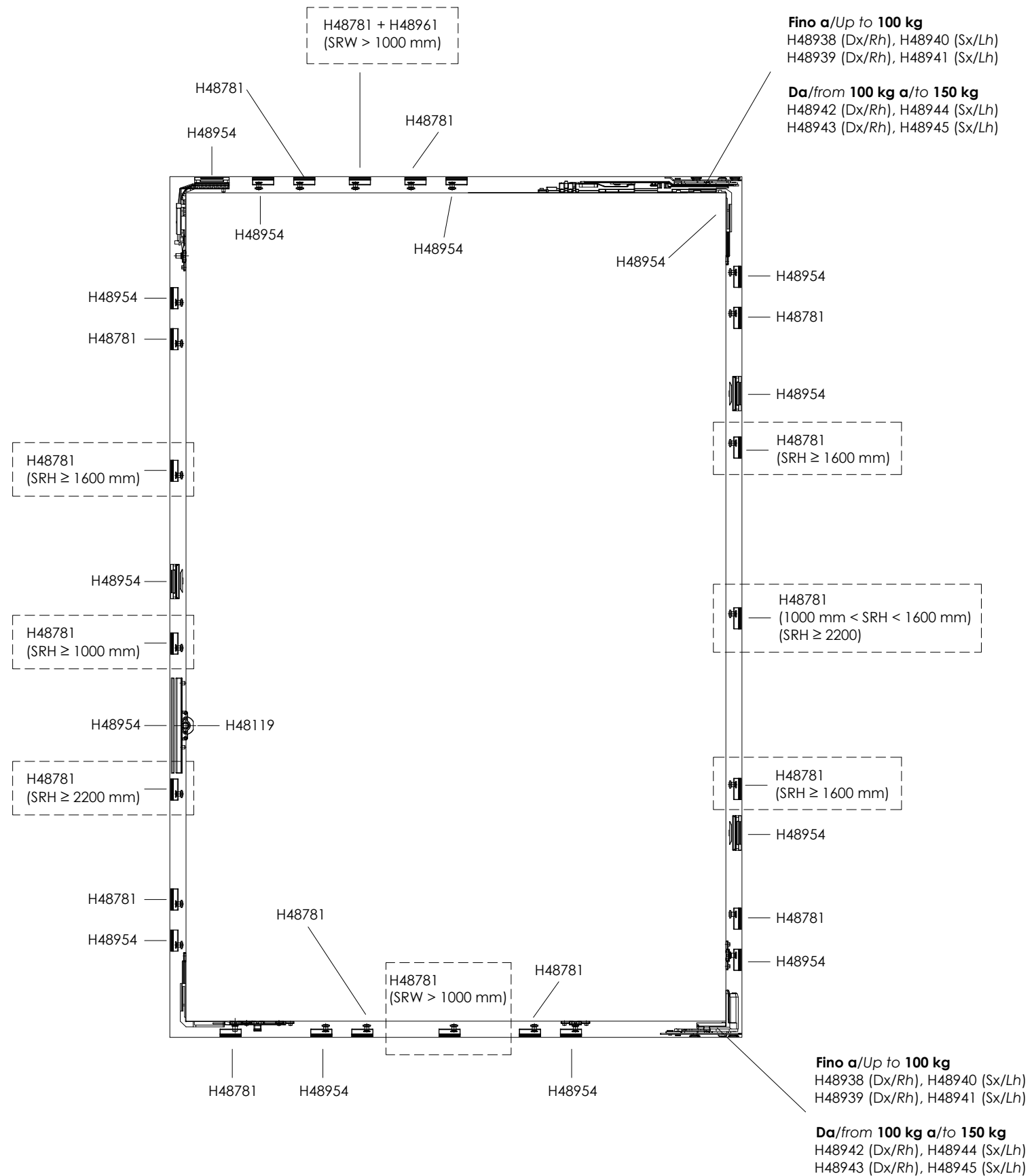
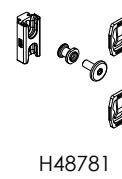
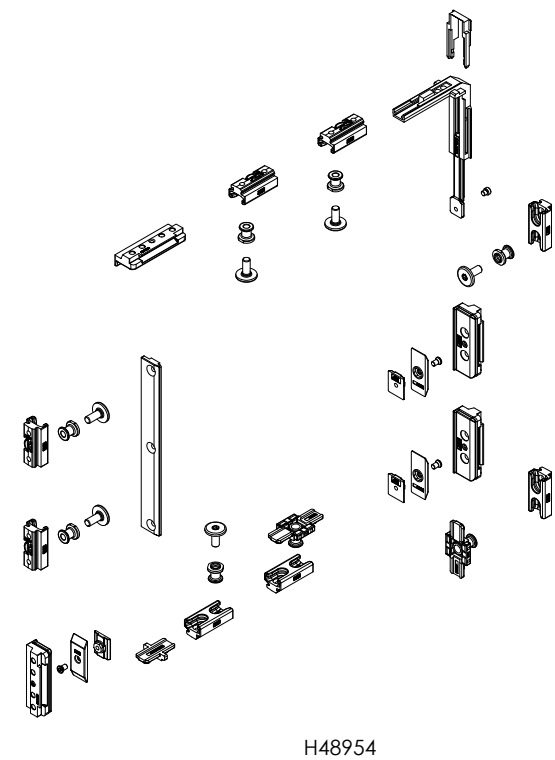

➤ RC3 - SCHEMA FERRAMENTA - FINESTRA BATTENTE aK+ 100kg / 150 kg  
 RC3 - HARDWARE SCHEME - TURN ONLY aK+ 100 kg / aK+ 150 kg

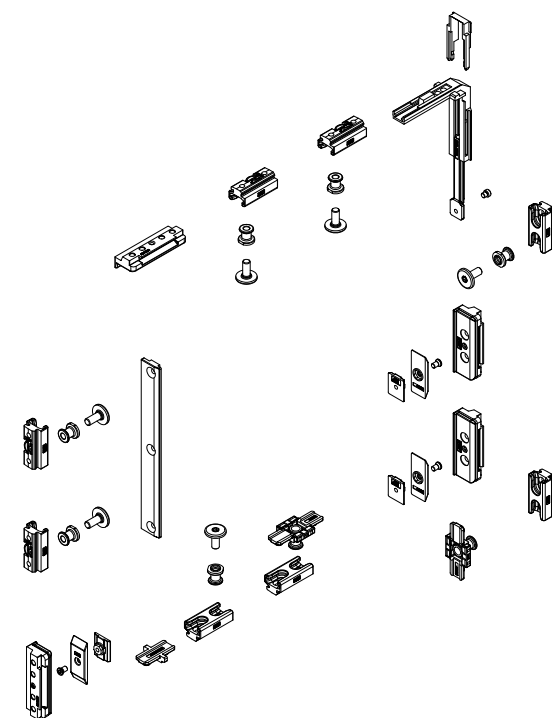

H48954

H48958

H48781

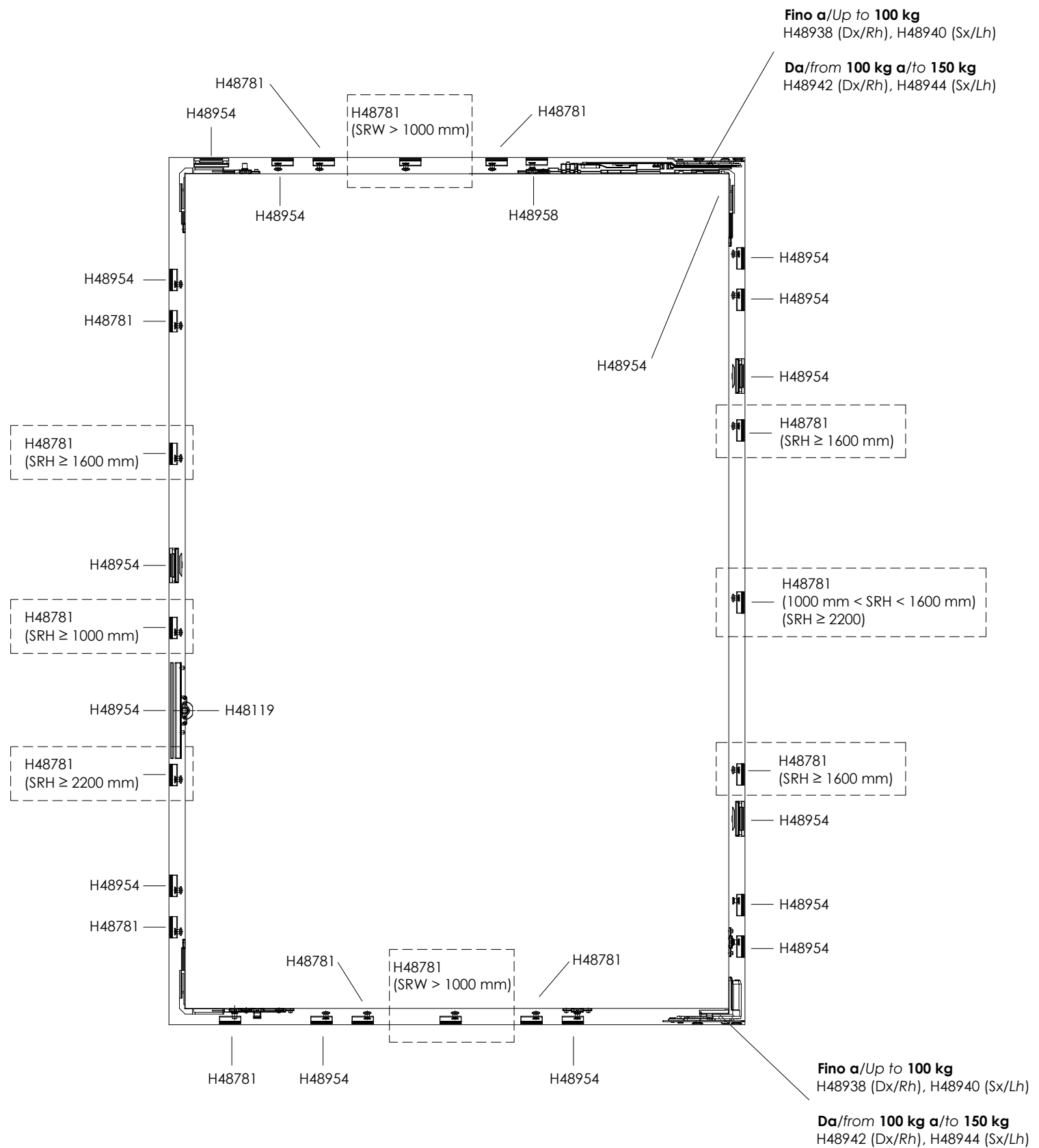

➤ RC3 - SCHEMA FERRAMENTA - FINESTRA DUE ANTE αK+ 100kg / 150 kg  
 RC3 - HARDWARE SCHEME - TURN ONLY SECOND SASH αK+ 100 kg / αK+ 150 kg

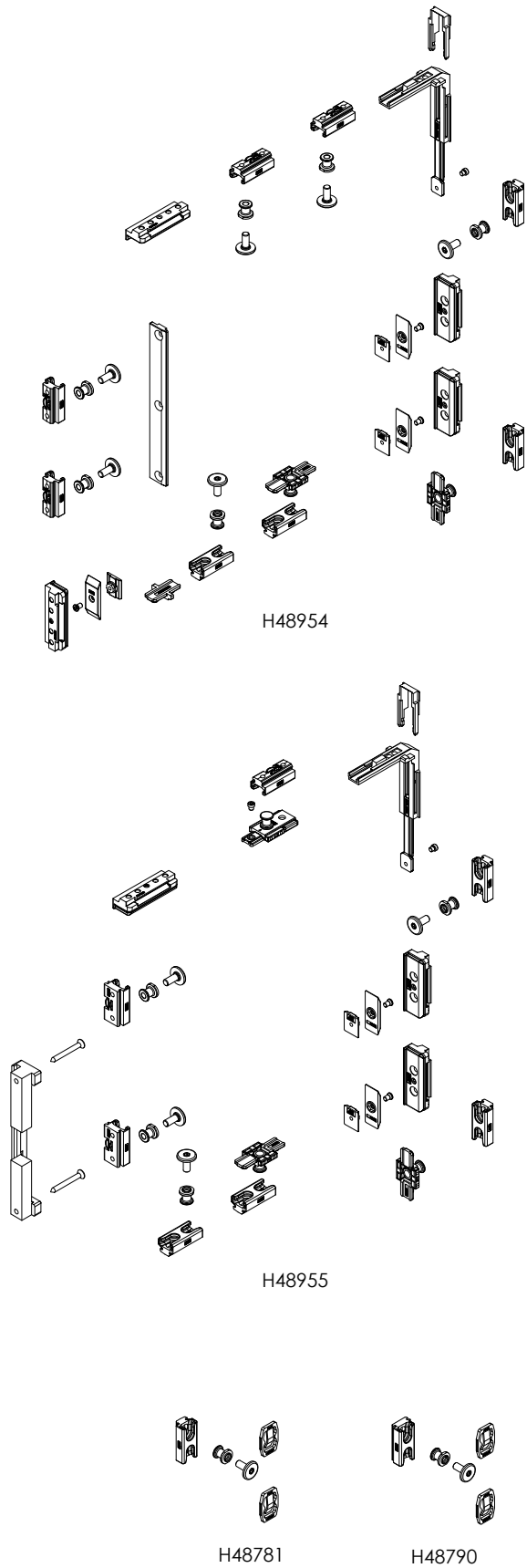

**Fino α/Up to 100 kg**  
 H48938 (Dx/Rh), H48940 (Sx/Lh)  
**Da/from 100 kg α/to 150 kg**  
 H48942 (Dx/Rh), H48944 (Sx/Lh)

**Fino α/Up to 100 kg**  
 H48938 (Dx/Rh), H48940 (Sx/Lh)  
 H48939 (Dx/Rh), H48941 (Sx/Lh)  
**Da/from 100 kg α/to 150 kg**  
 H48942 (Dx/Rh), H48944 (Sx/Lh)  
 H48943 (Dx/Rh), H48945 (Sx/Lh)

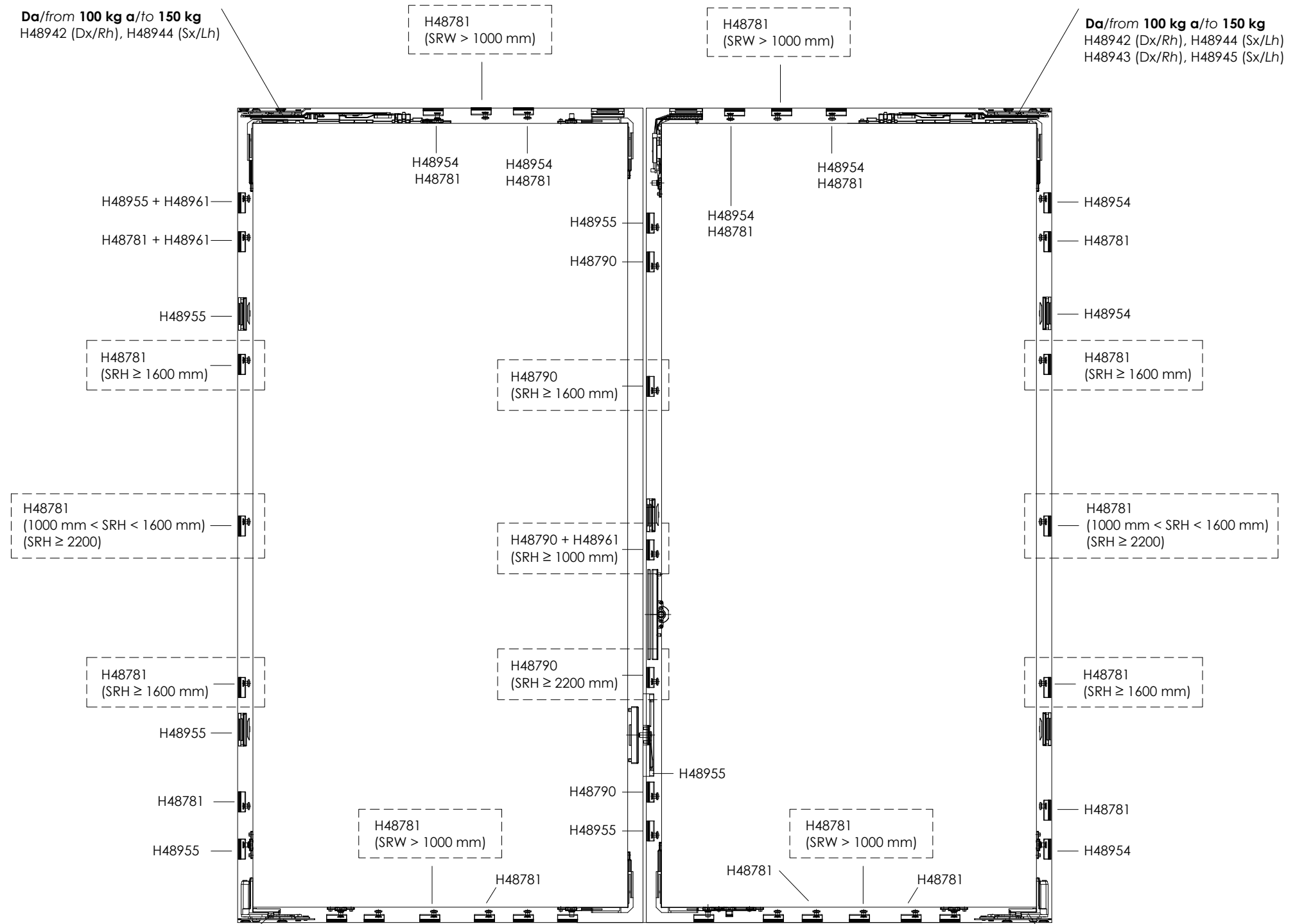

**Fino α/Up to 100 kg**  
 H48938 (Dx/Rh), H48940 (Sx/Lh)  
**Da/from 100 kg α/to 150 kg**  
 H48942 (Dx/Rh), H48944 (Sx/Lh)

**Fino α/Up to 100 kg**  
 H48938 (Dx/Rh), H48940 (Sx/Lh)  
 H48939 (Dx/Rh), H48941 (Sx/Lh)  
**Da/from 100 kg α/to 150 kg**  
 H48942 (Dx/Rh), H48944 (Sx/Lh)  
 H48943 (Dx/Rh), H48945 (Sx/Lh)



➤ **DISTINTA DI TAGLIO ASTE**  
**RODS CUTTING LIST**

**L1.1**

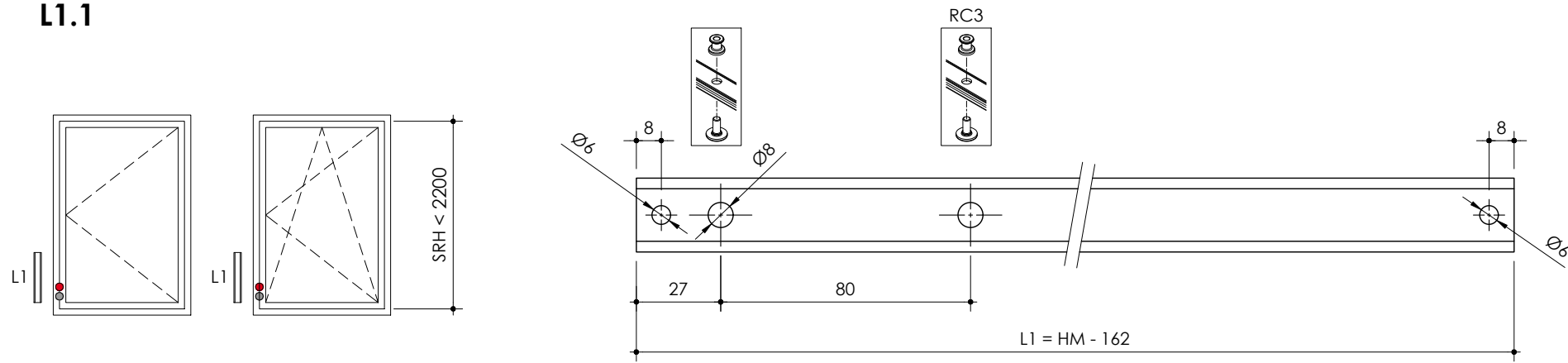

**L1.2**

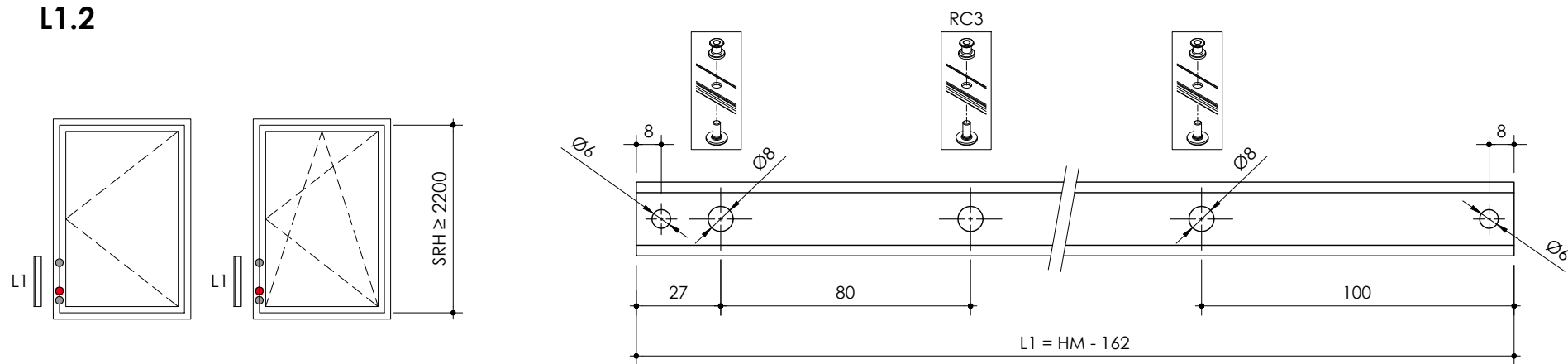

**L2.1**

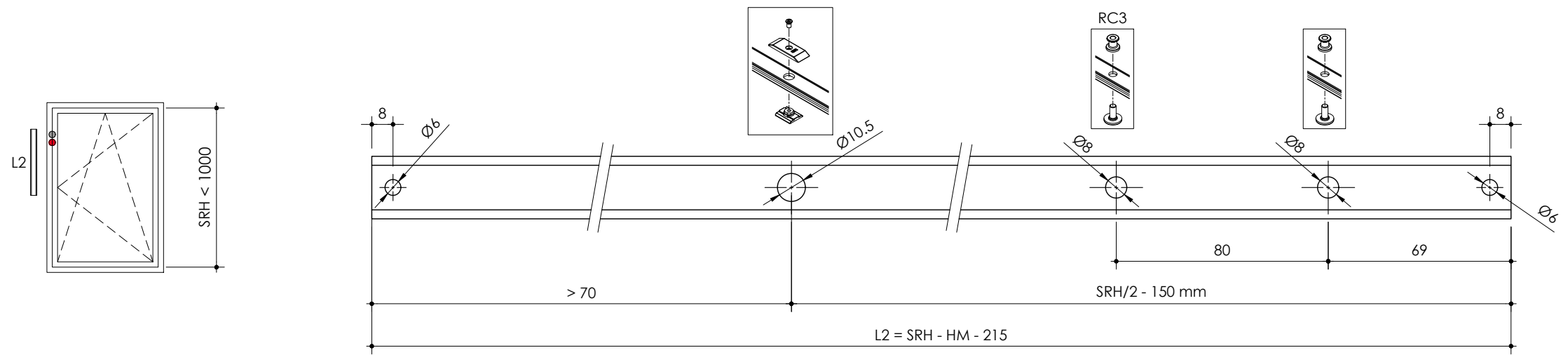

➤ **DISTINTA DI TAGLIO ASTE**  
**RODS CUTTING LIST**

**L2.2**

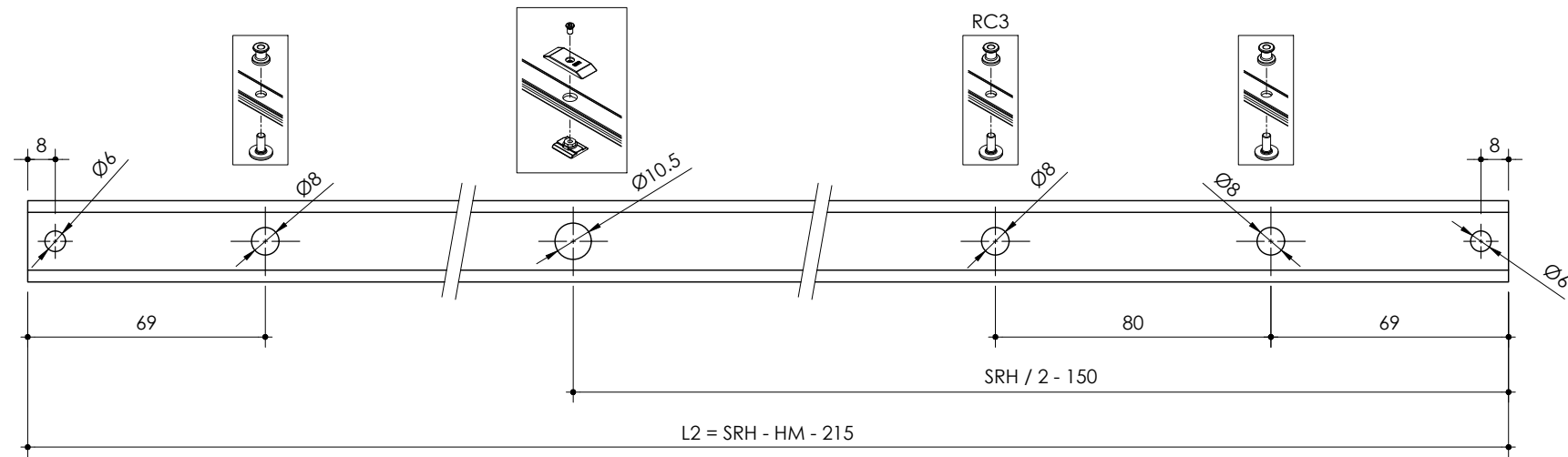
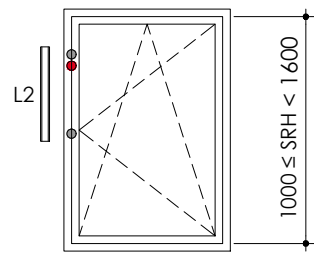

**L2.3**

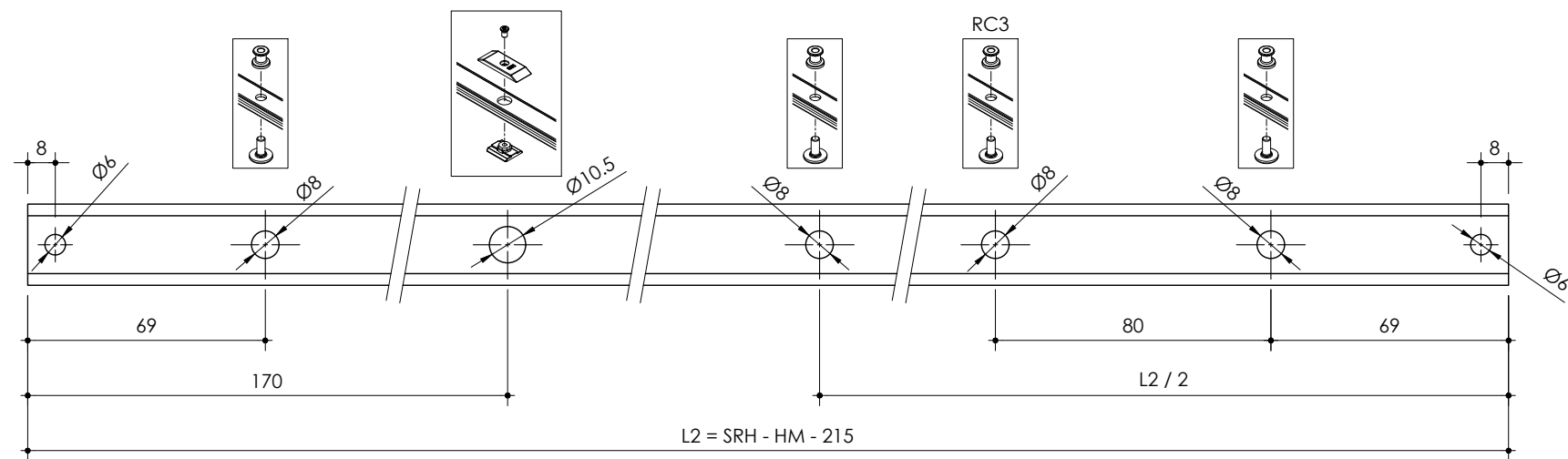
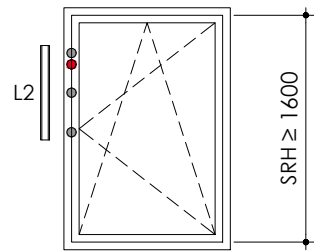

**L2.4**

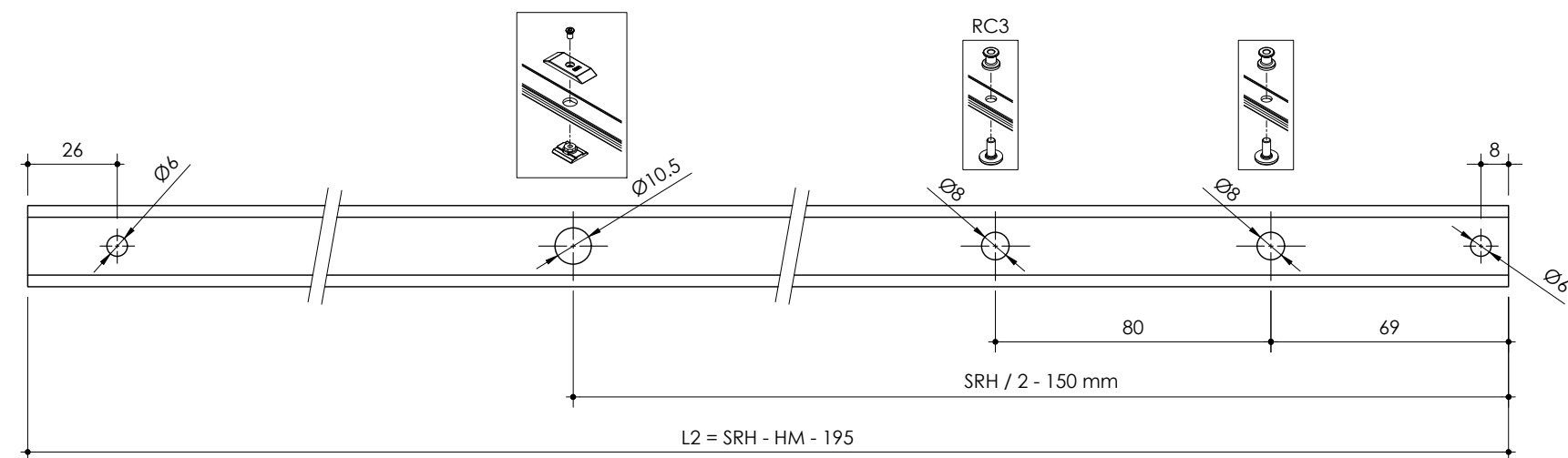
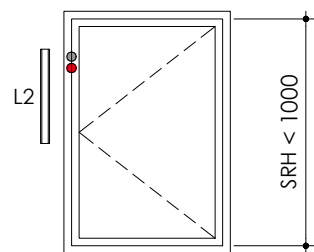

➤ **DISTINTA DI TAGLIO ASTE**  
**RODS CUTTING LIST**

**L2.5**

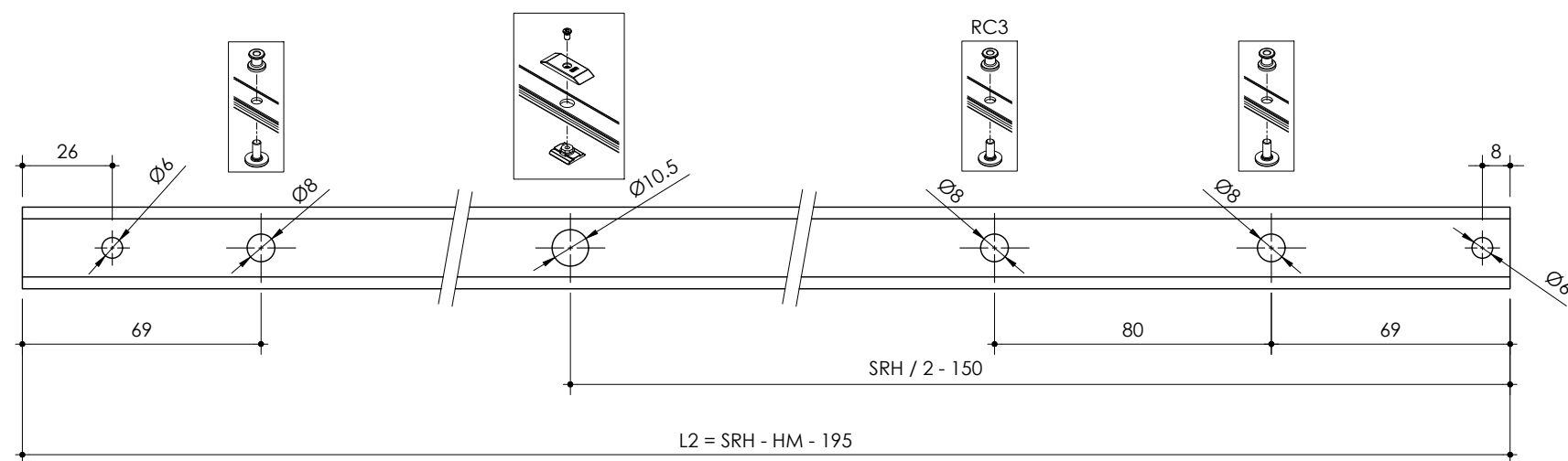
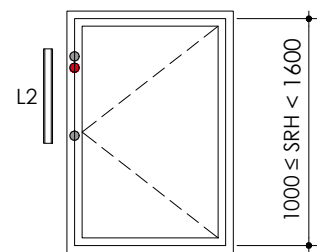

**L2.6**

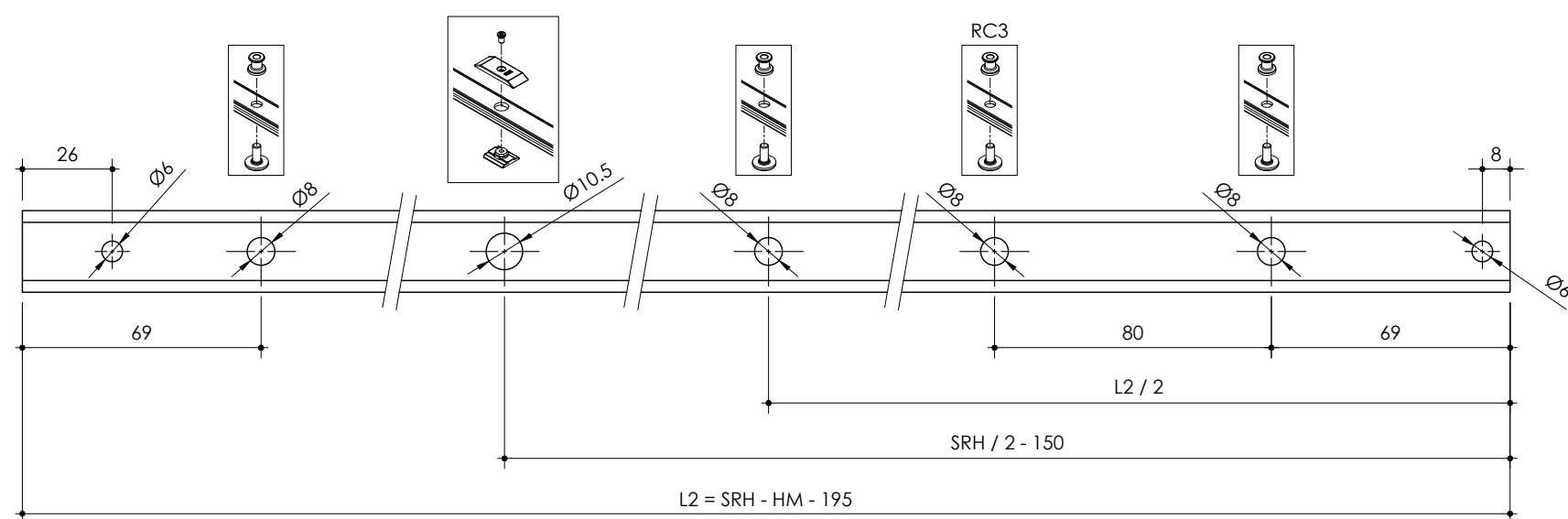
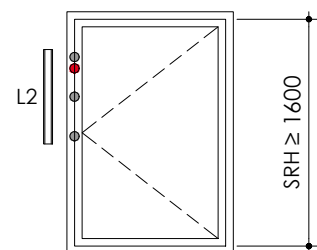

**L3.1 (H48926)**

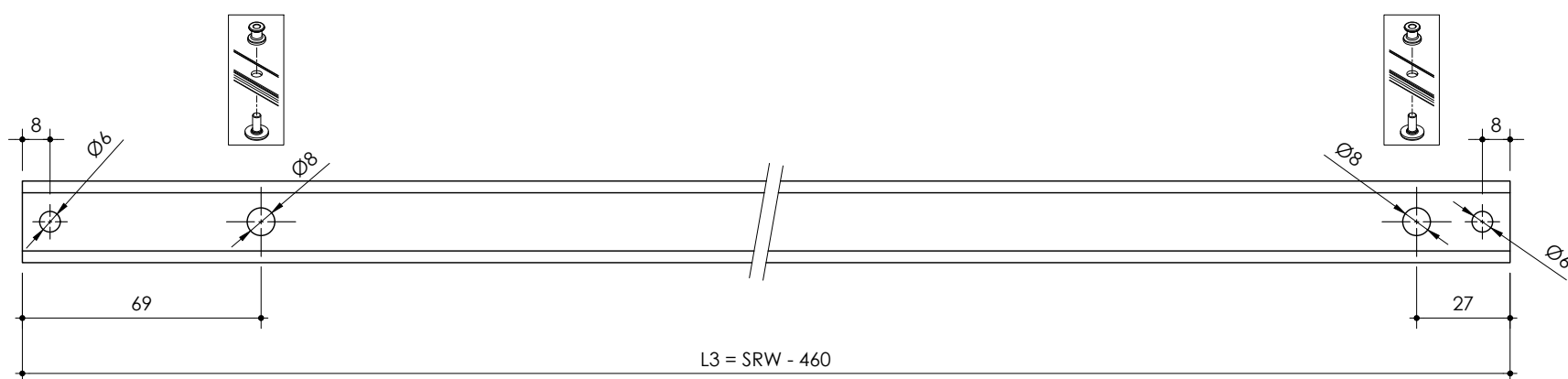
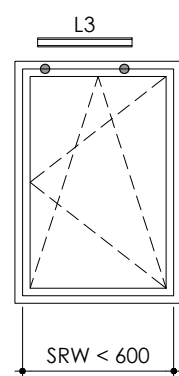

➤ **DISTINTA DI TAGLIO ASTE**  
**RODS CUTTING LIST**

**L3.2 (H48927)**

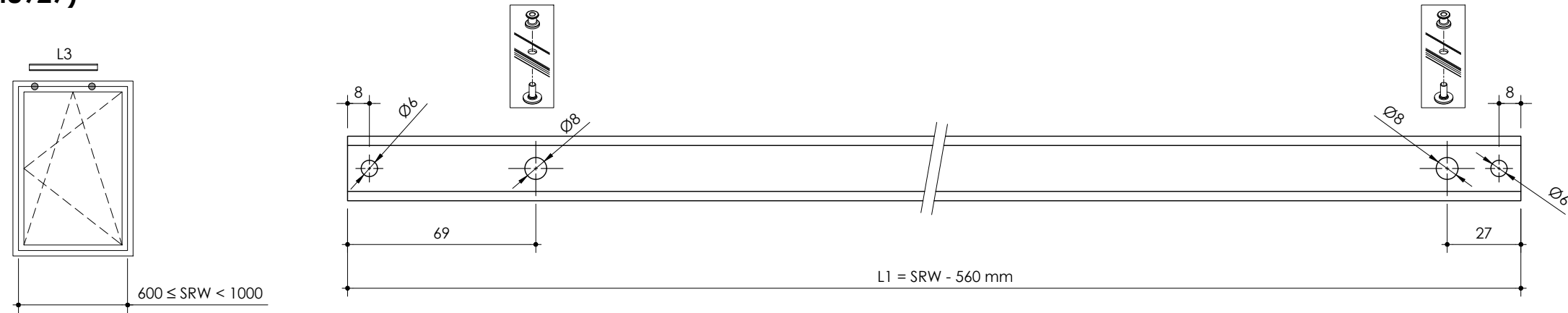

**L3.3 (H48927+H48614/H48929)**

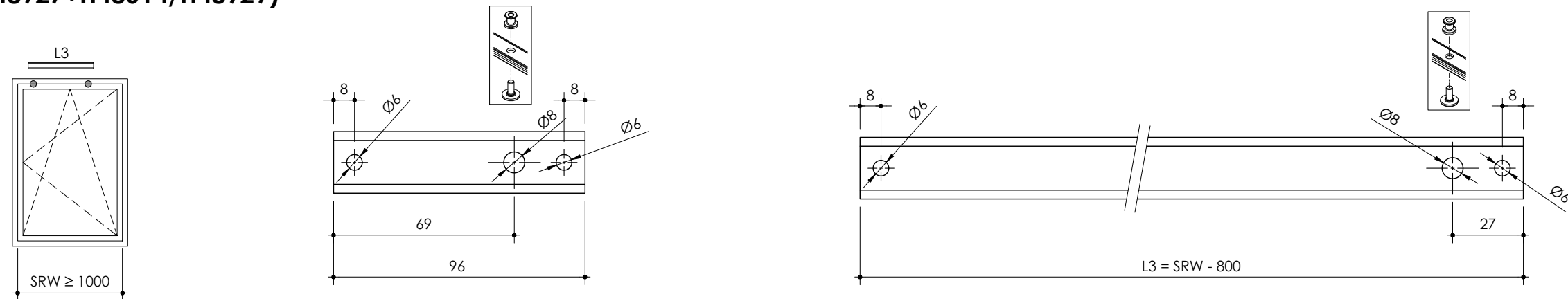

**L3.4 (H48930/931)**

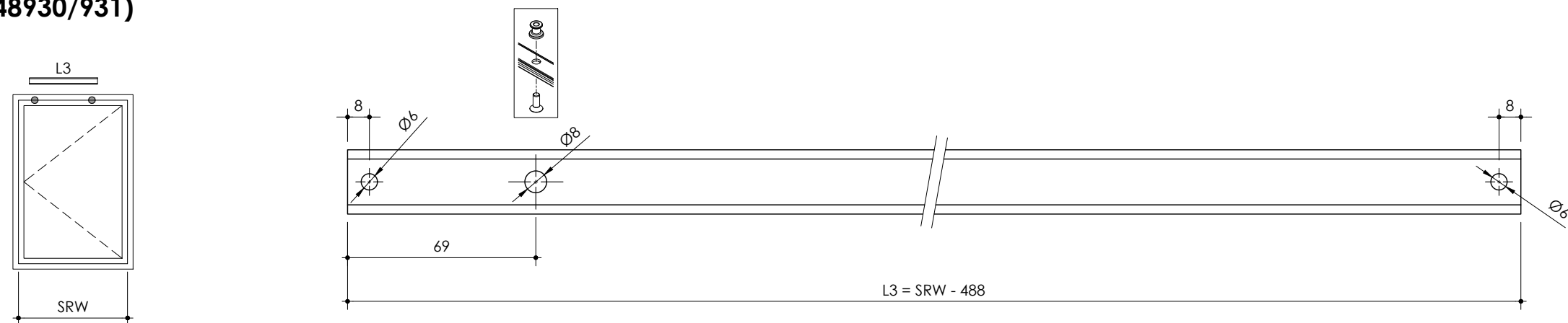

➤ **DISTINTA DI TAGLIO ASTE**  
**RODS CUTTING LIST**

**L3.5 (H48939/941/943/945)**

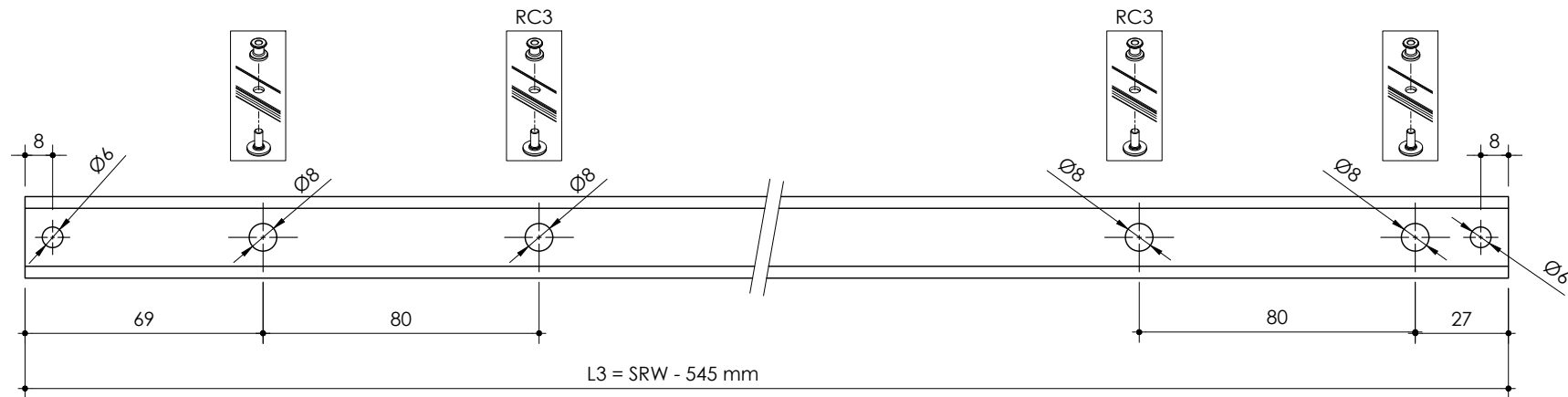
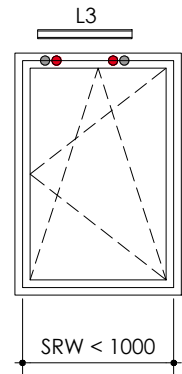

**L3.6 (H48939/941/943/945)**

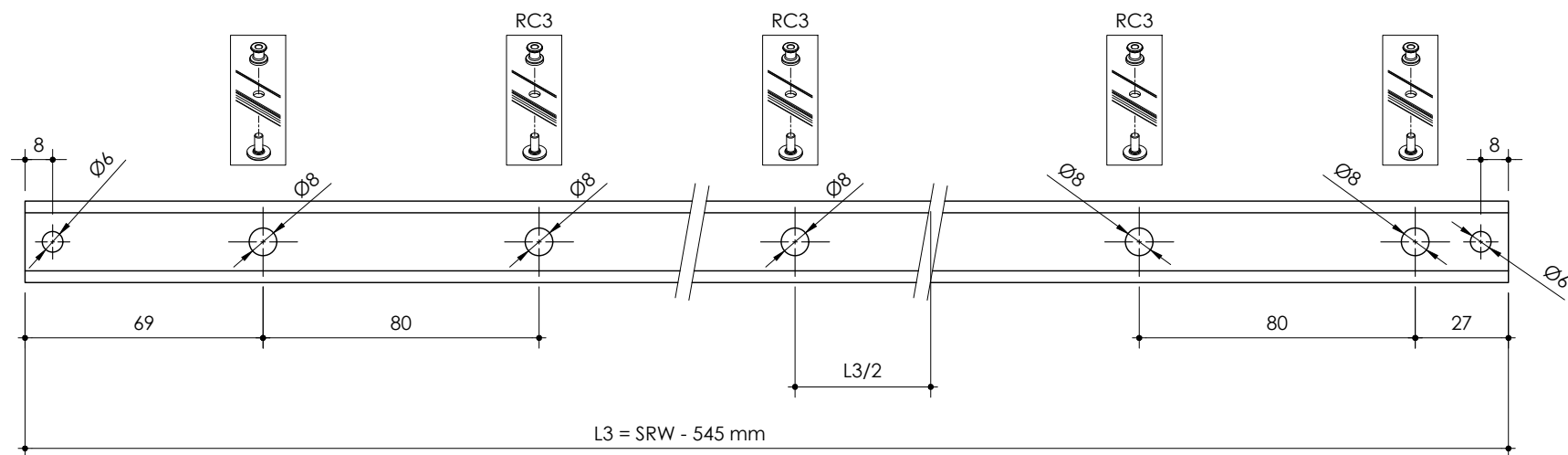
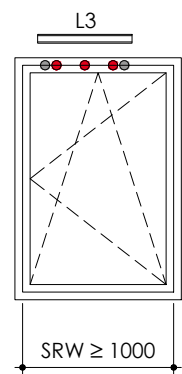

**L4.1**

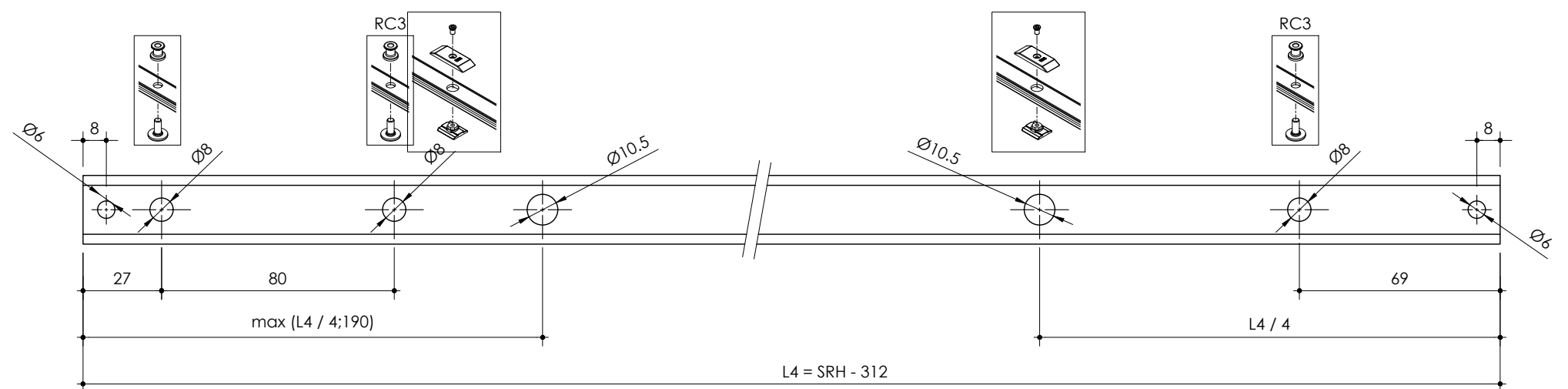
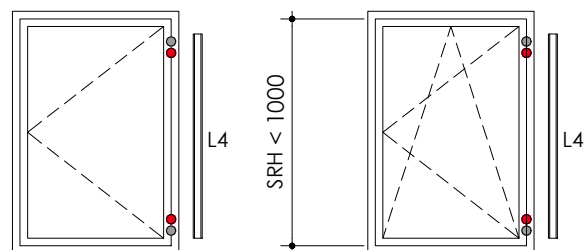

▶ **DISTINTA DI TAGLIO ASTE**  
**RODS CUTTING LIST**

**L4.2**

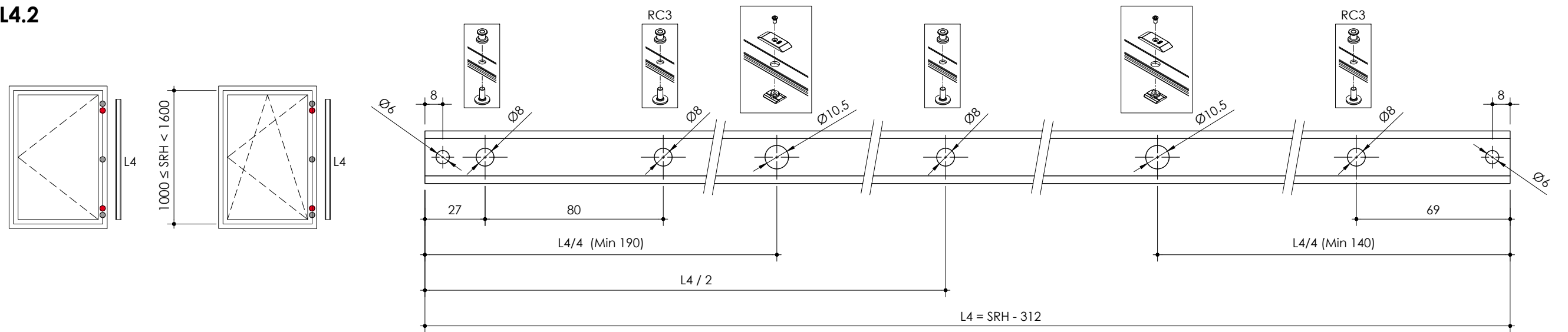

**L4.3**

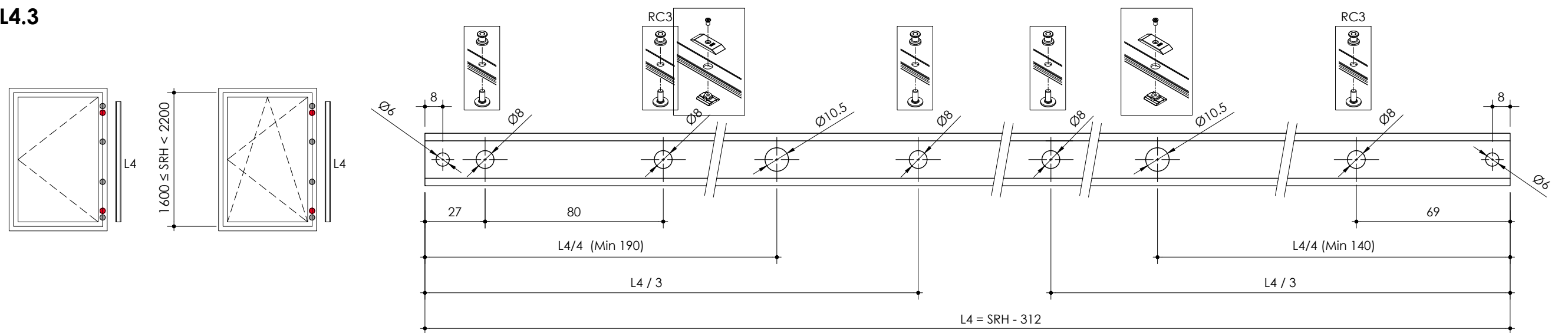

**L4.4**

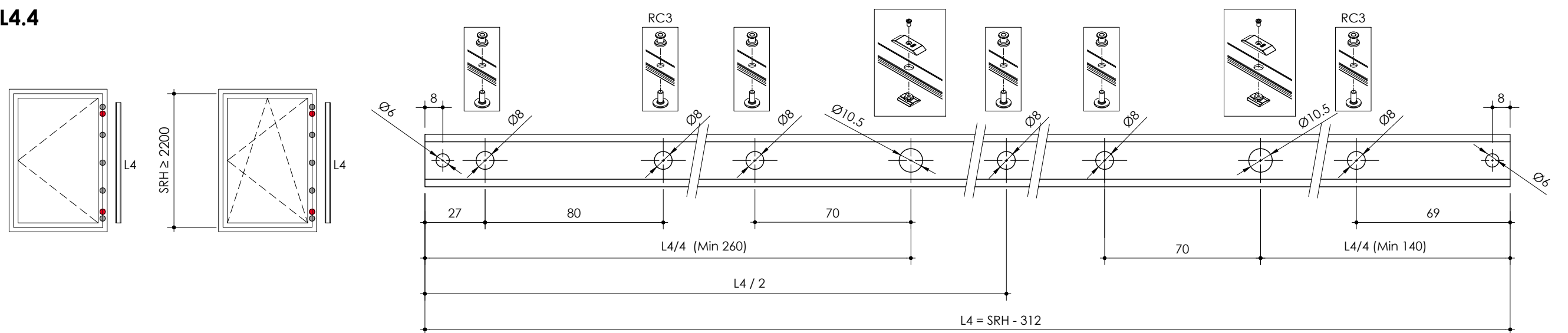

➤ **DISTINTA DI TAGLIO ASTE**  
**RODS CUTTING LIST**

**L5.1 (H48341/342 & H48345/346)**

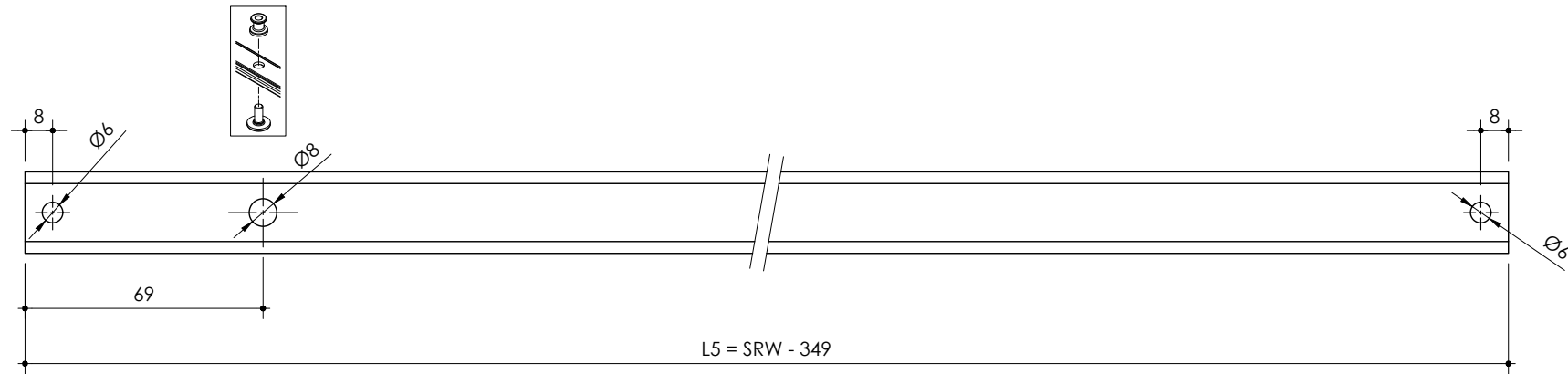
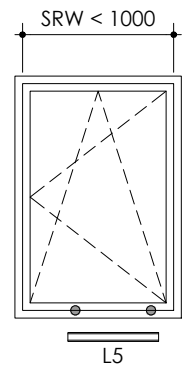

**L5.2 (H48341/342 & H48345/346)**

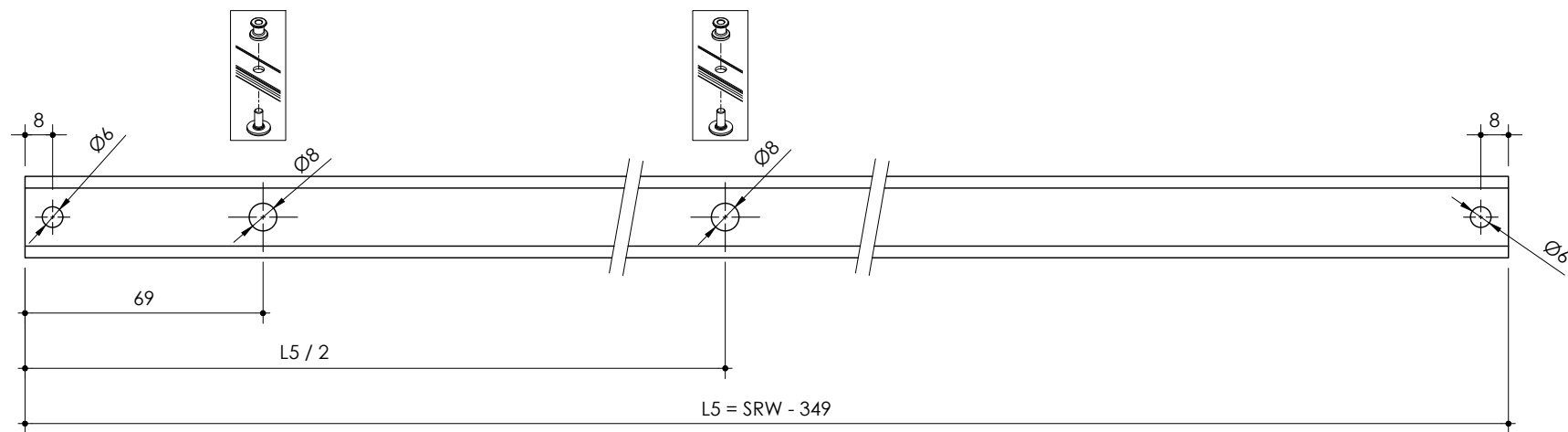
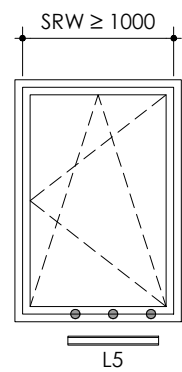

**L5.3 (H48341/342 & H48345/346)**

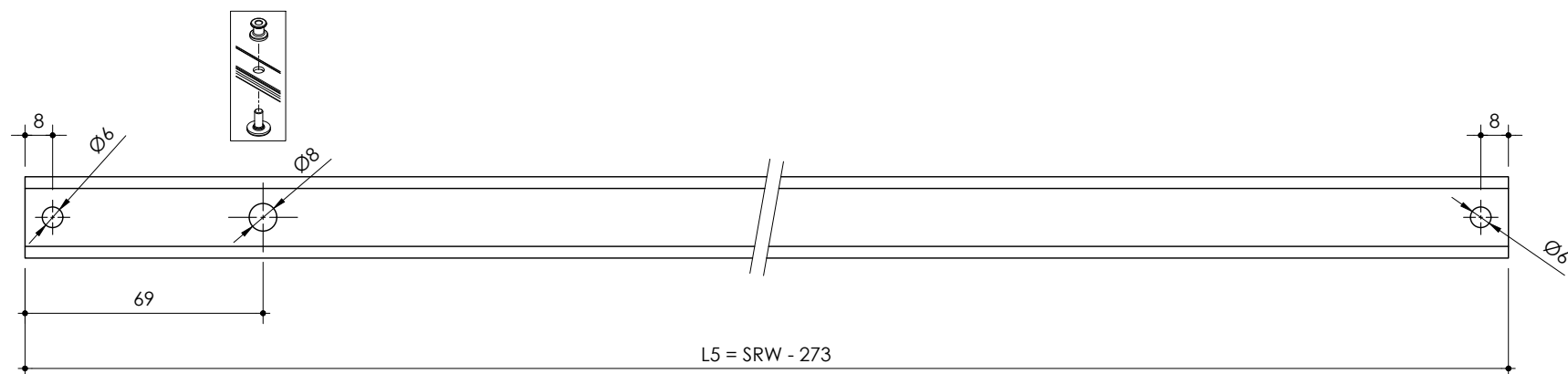
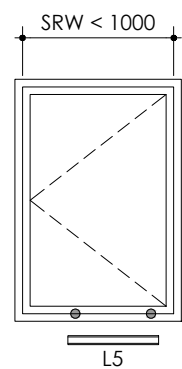

➤ **DISTINTA DI TAGLIO ASTE**  
**RODS CUTTING LIST**

**L5.4 (H48341/342 & H48345/346)**

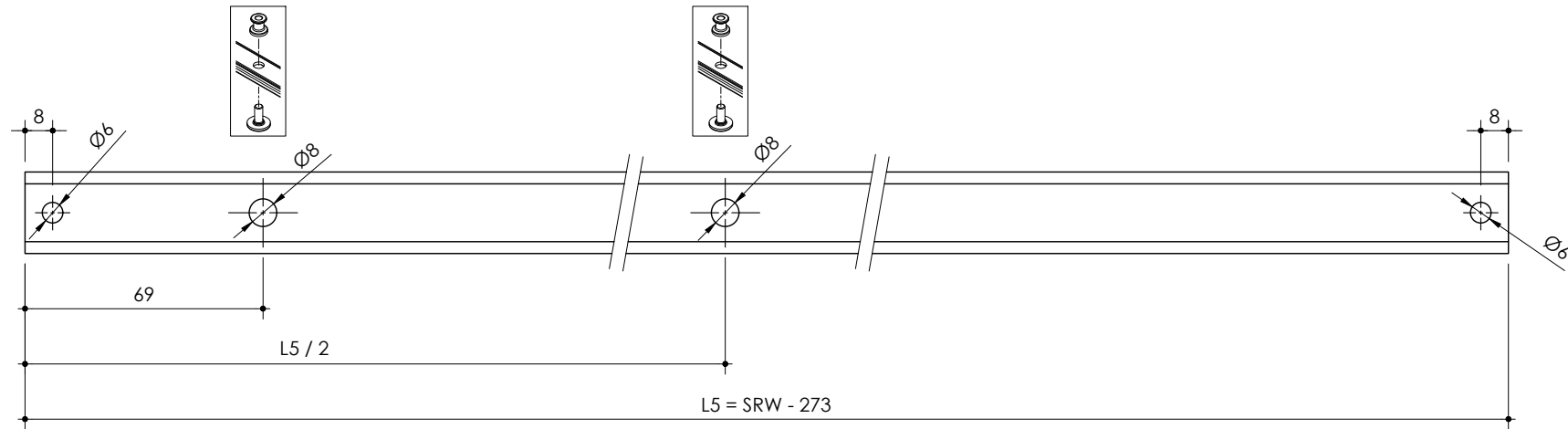
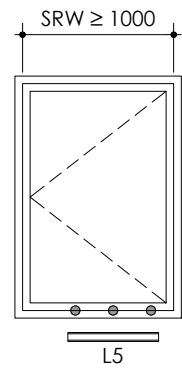

**L5.5 (H48939/941/943/945)**

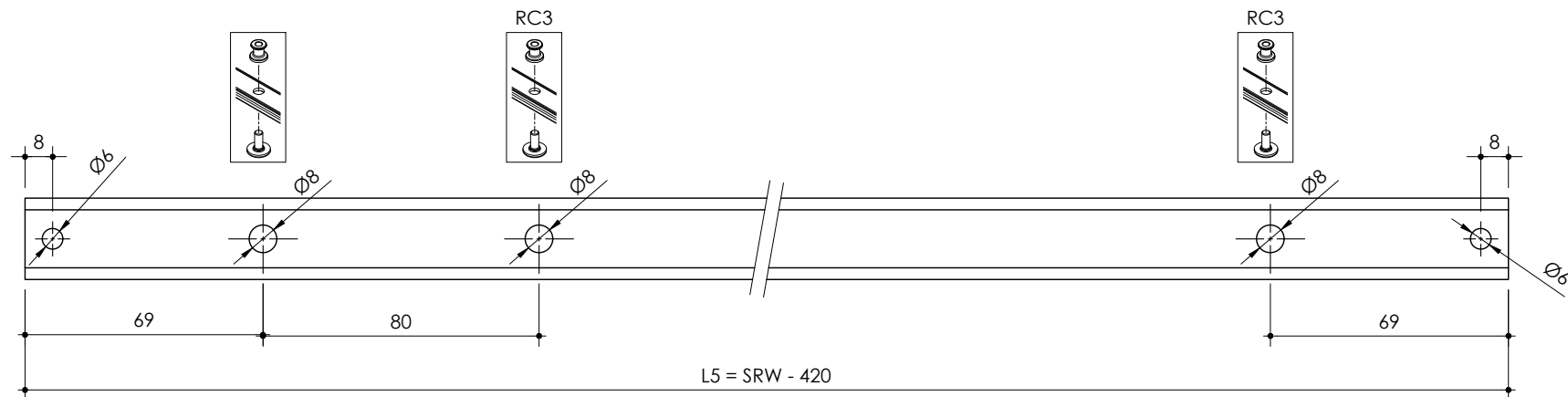
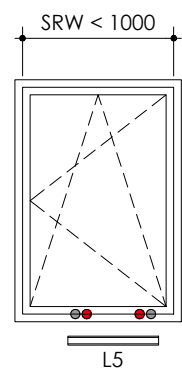

**L5.6 (H48939/941/943/945)**

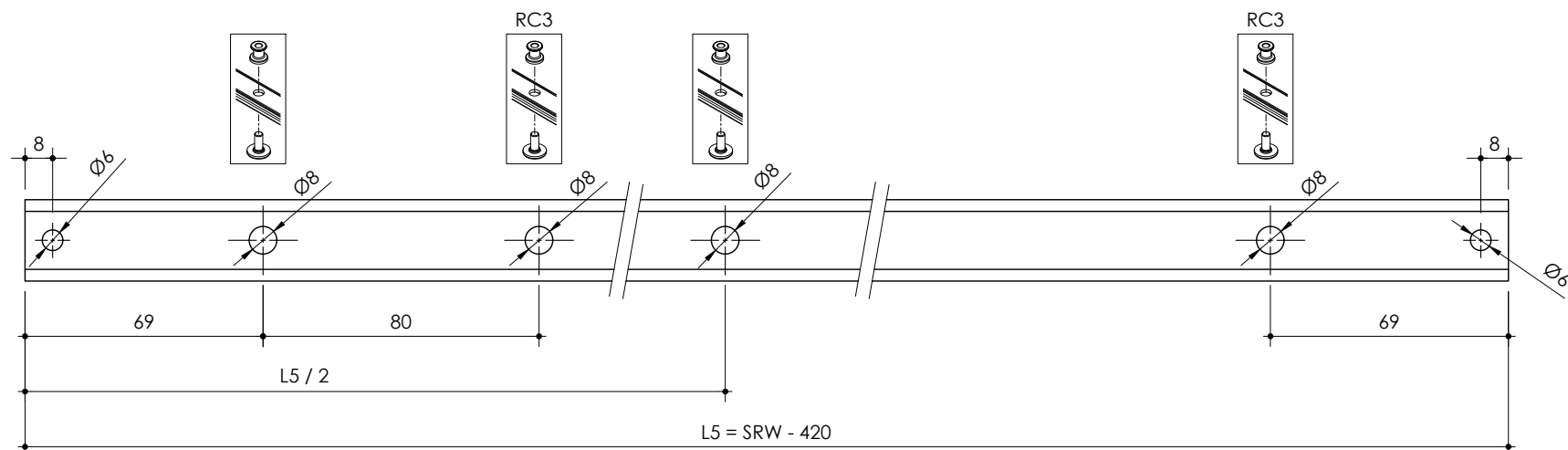
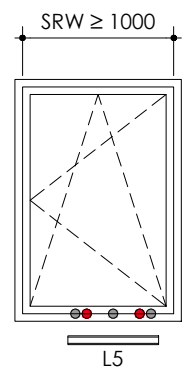

➤ **DISTINTA DI TAGLIO ASTE**  
**RODS CUTTING LIST**

**L6**

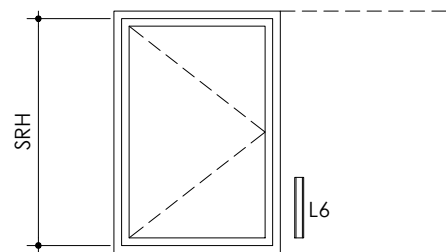

**ATTENZIONE!**

FARE UN'ASOLA DI 50 mm IN CORRISPONDENZA DELLE VITI DI FISSAGGIO DELLO STULP E DEGLI INCONTRI

**WARNING!**

PREPARE 50 mm SLOT IN CORRISPONDENZA TO THE FIXING SCREWS OF THE STULP AND THE STRIKERS

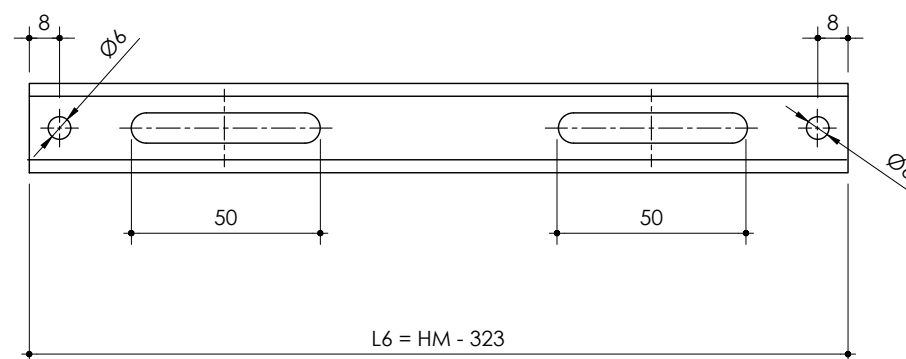

**L7**

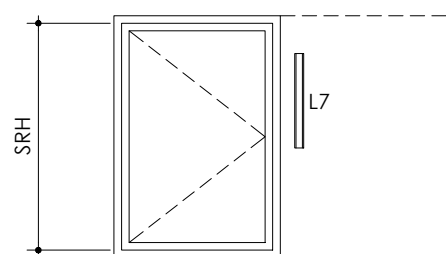

**ATTENZIONE!**

FARE UN'ASOLA DI 50 mm IN CORRISPONDENZA DELLE VITI DI FISSAGGIO DELLO STULP E DEGLI INCONTRI

**WARNING!**

PREPARE 50 mm SLOT IN CORRISPONDENZA TO THE FIXING SCREWS OF THE STULP AND THE STRIKERS

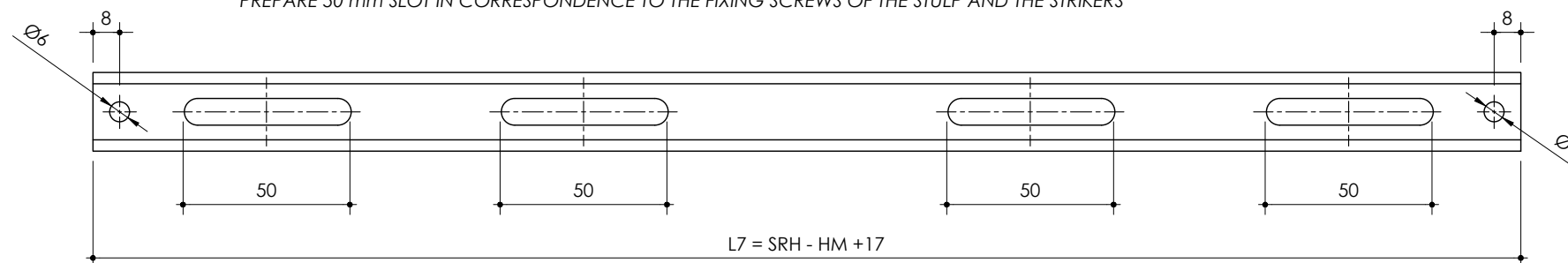

**L8.1 (H48930/931)**

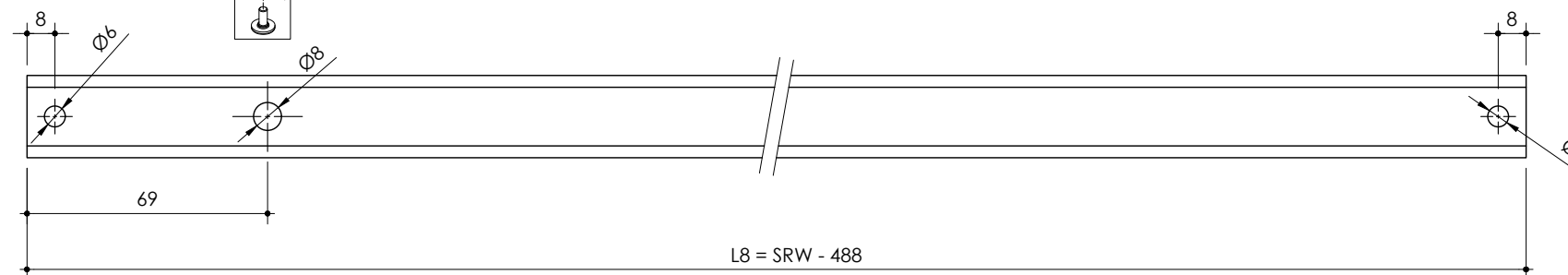
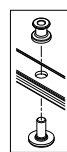
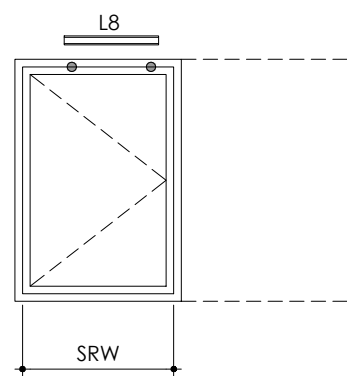

➤ **DISTINTA DI TAGLIO ASTE**  
**RODS CUTTING LIST**

**L8.2 (H48939/941/943/945)**

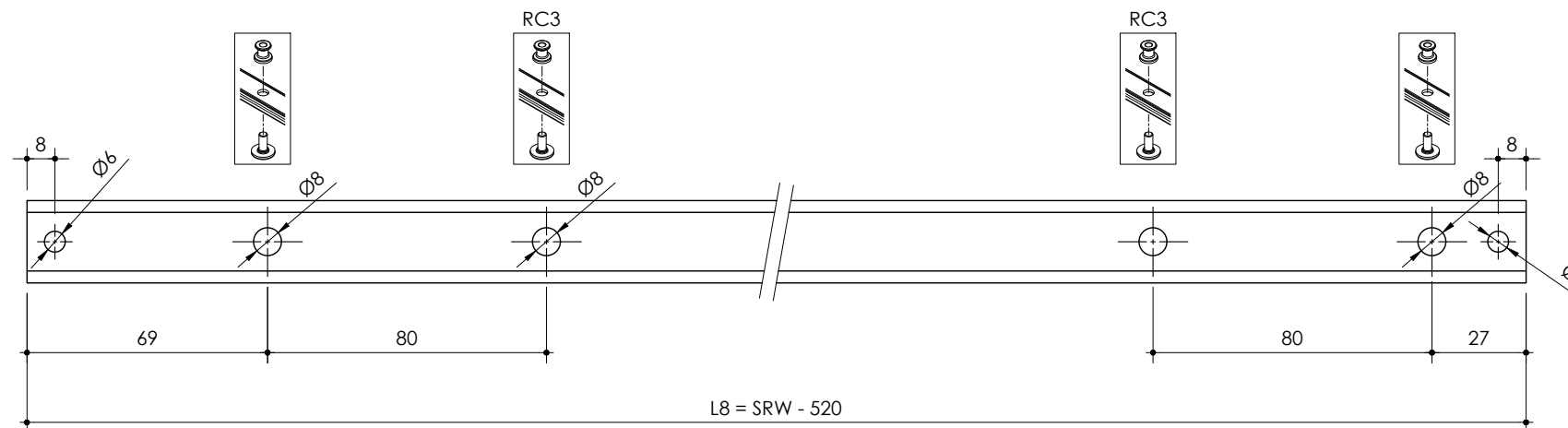
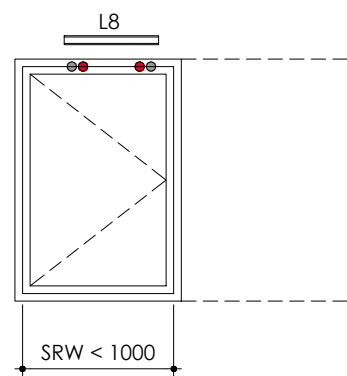

**L8.3 (H48939/941/943/945)**

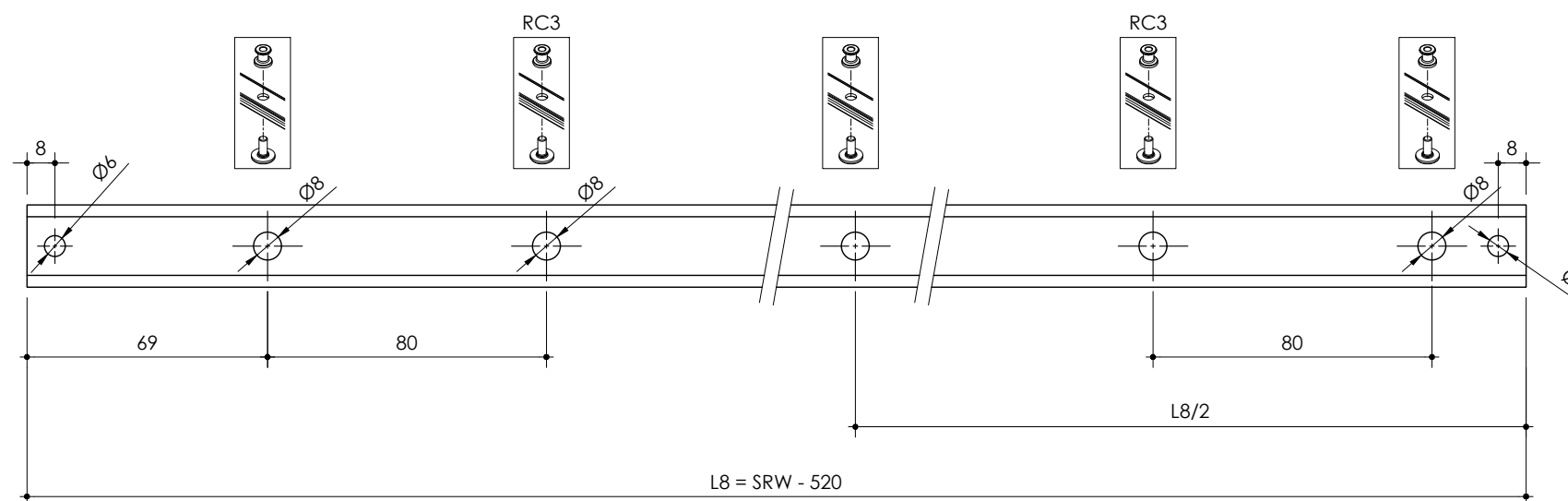
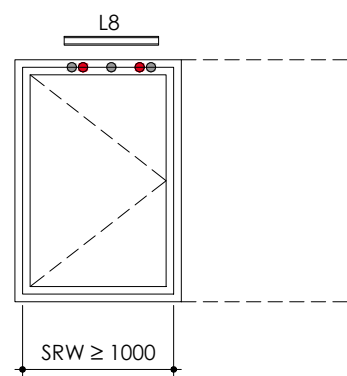

RC2/RC3 - SCHEMA DISTANZIATORI  
RC2/RC3 - SPACER DIAGRAM

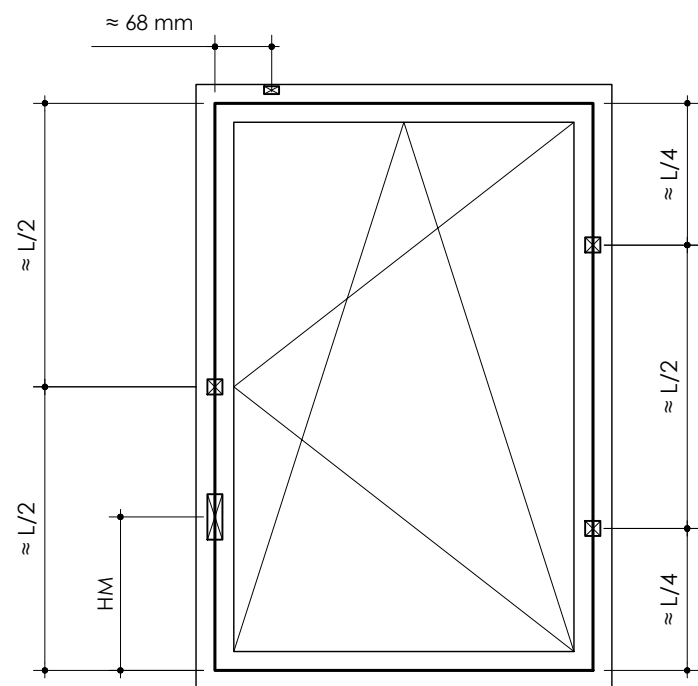

PER LA POSIZIONE ESATTA DEI DISTANZIALI,  
FARE RIFERIMENTO ALLE PAGINE DELLE DISTINTE DI TAGLIO DELLE ASTE

FOR THE EXACT POSITION OF THE SPACERS,  
PLEASE REFER TO RODS CUTTING LIST PAGES

	RC2	RC3
HM <sub>Min</sub>	450	520

REGOLARE CON LA VITE DI FISSAGGIO,  
POI FISSARE CON 2 x ISO 7050  
ADJUST WITH SET SCREW THEN FIX  
WITH 2 x ISO 7050

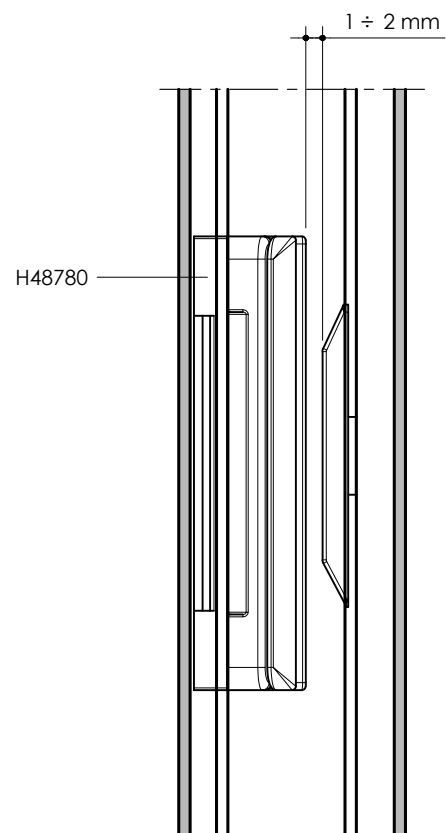
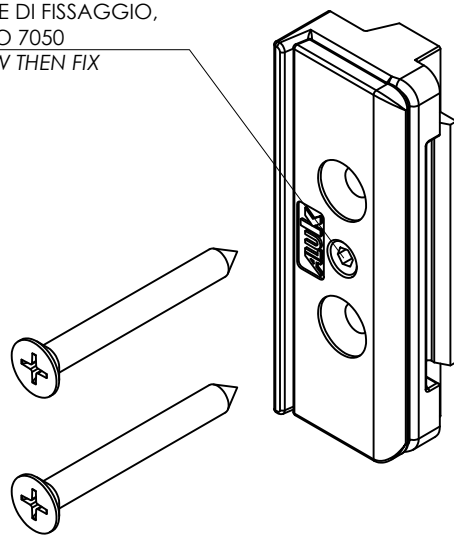

ALLINEARE IL DISTANZIATORE CON IL RINVIO D'ANGOLO  
ALIGN SPACER WITH CORNER DRIVE

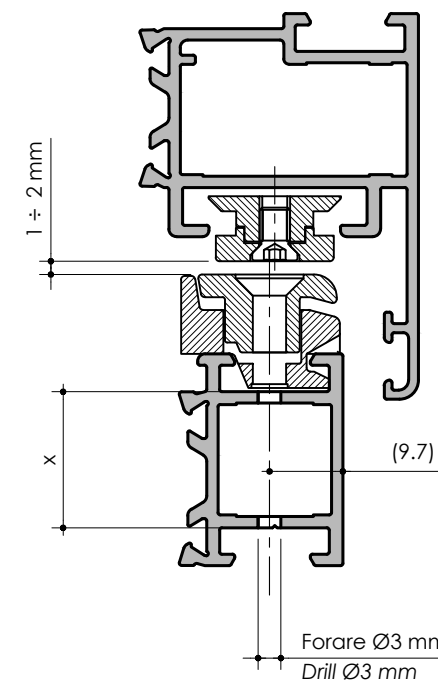
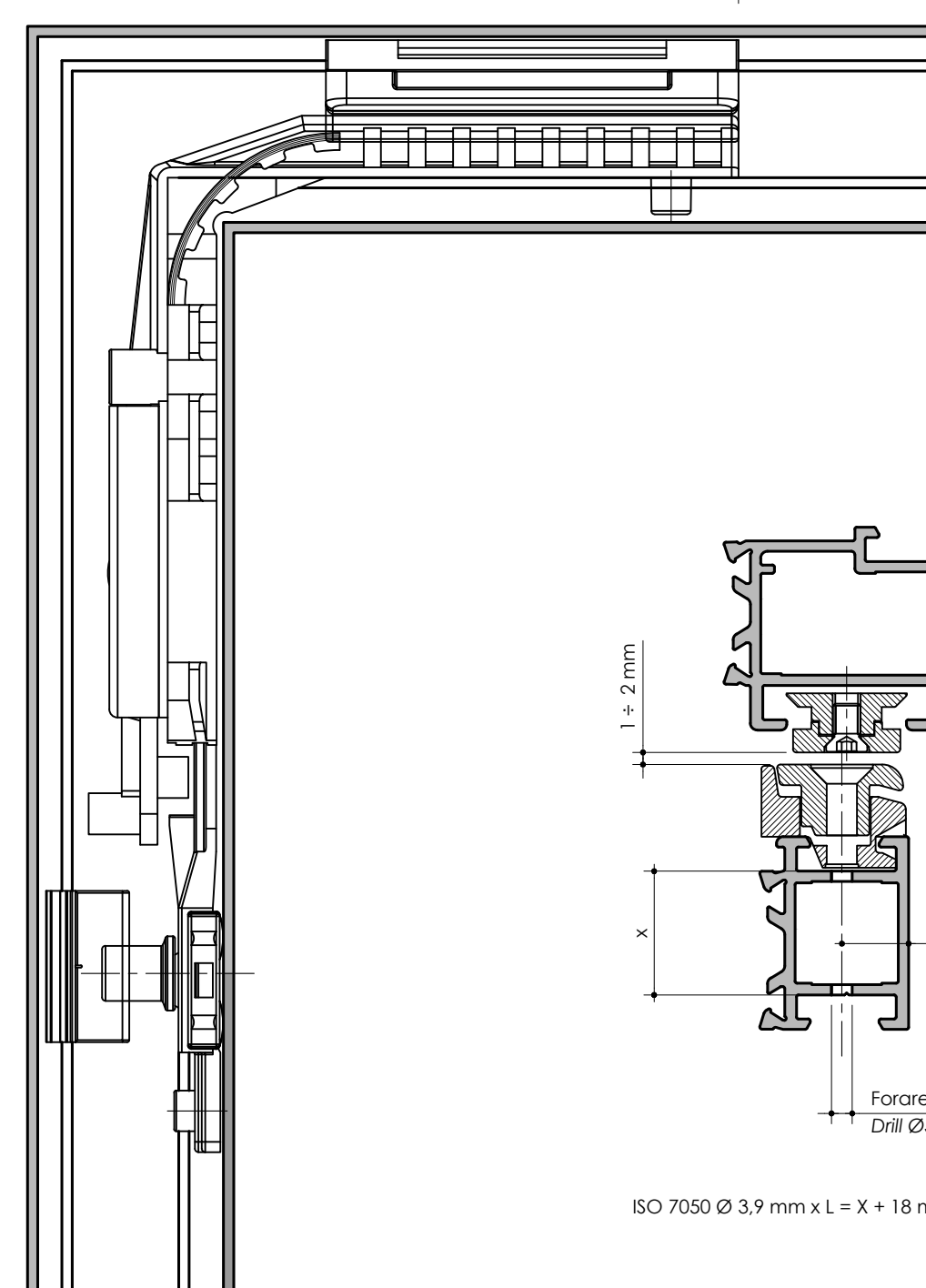

ISO 7050 Ø 3,9 mm x L = X + 18 mm INOX A2-70

➤ RC2/RC3 - ASSEMBLAGGIO DISTANZIATORI E NOTTOLINI  
RC2/RC3 - MUSHROOM AND SPACER ASSEMBLING

**ATTENZIONE!** NELLE APPLICAZIONI RC2/RC3 USARE SOLO L'ASTA IN ALLUMINIO N48900

**WARNING!** FOR RC2/RC3 APPLICATION USE ONLY THE N48900 ALUMINIUM ROD

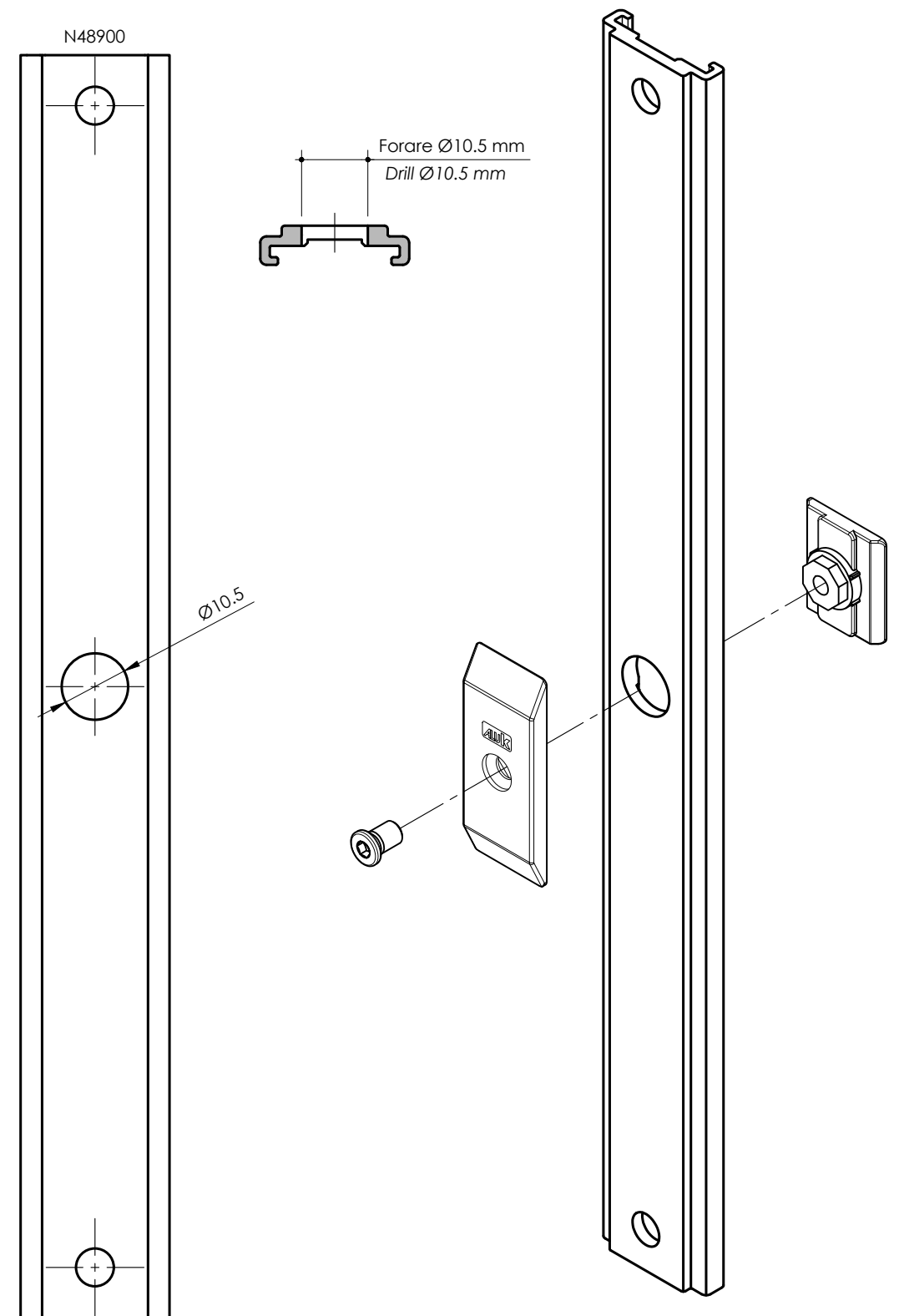
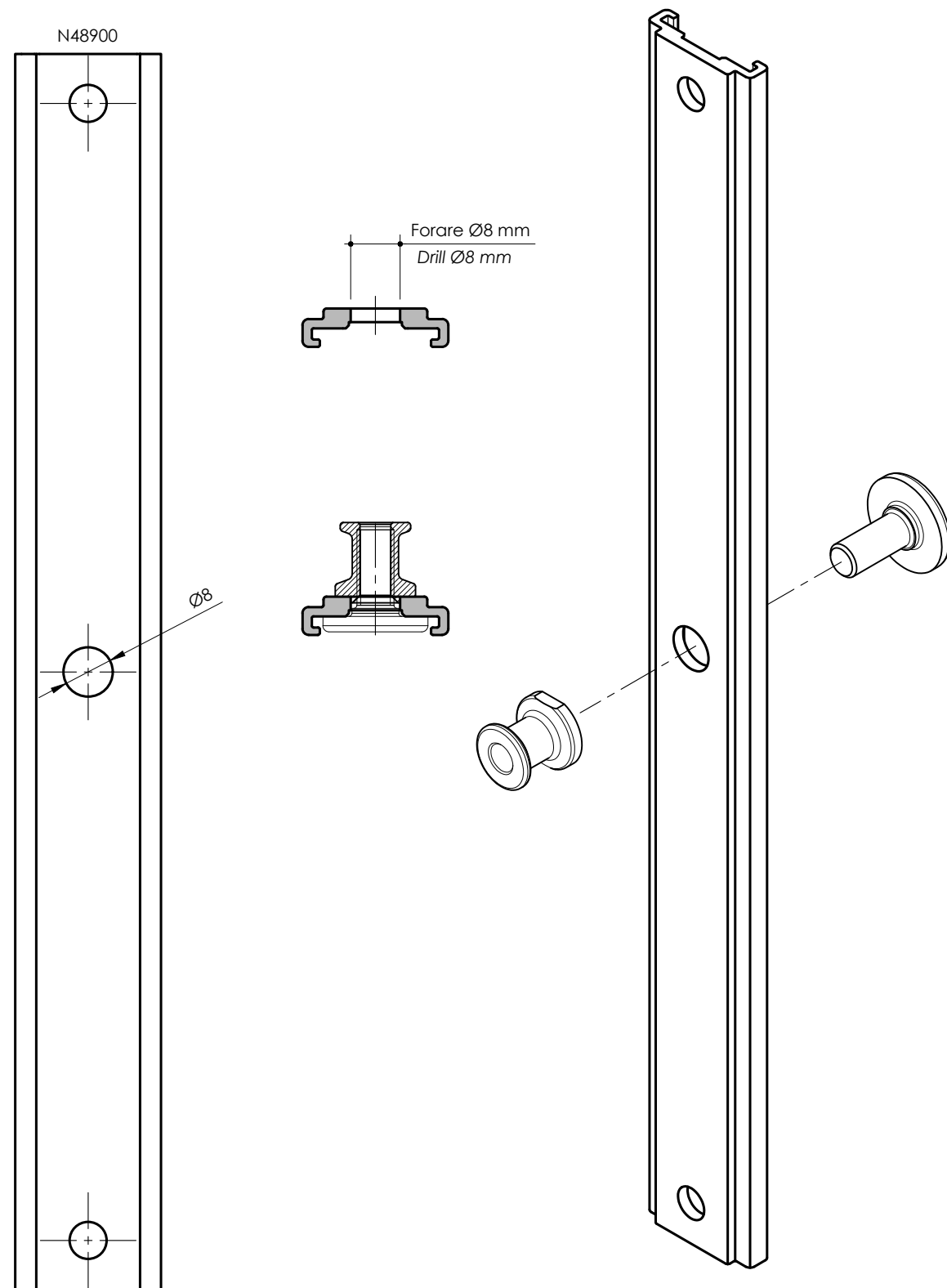

➤ **RC2/RC3 - POSIZIONAMENTO INCONTRI**  
**RC2/RC3 - STRIKER POSITIONING**

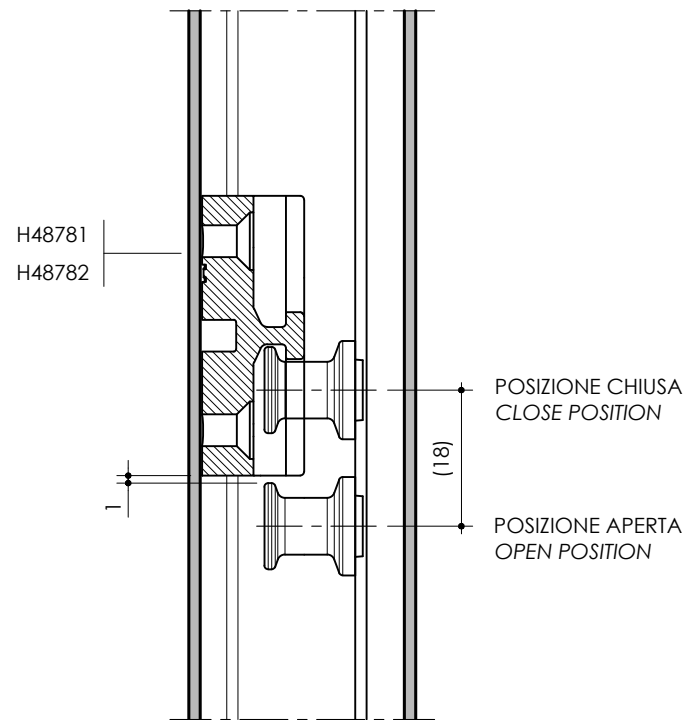

**POSIZIONE INCONTR**  
**STRIKER POSITION**

Scattare l'incontro in cava  
*Clip-in the striker in groove*

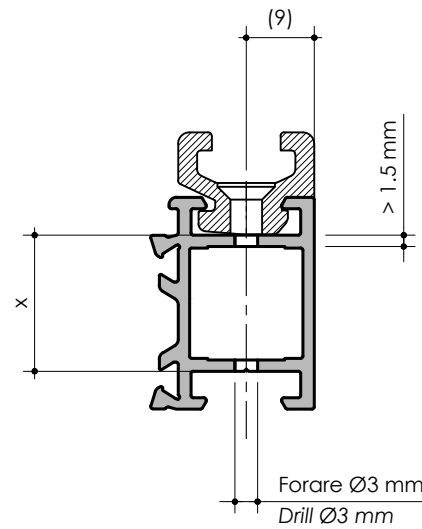

ISO 7050 Ø 3,9 mm x L = X + 10 mm INOX A2-70

**POSIZIONE INCONTR**  
**STRIKER POSITION**

Inserire l'incontro in cava  
*Slide-in the striker in groove*

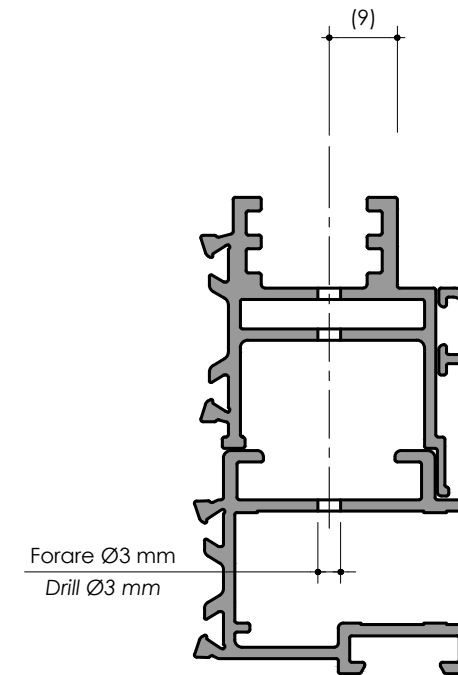

ISO 7050 Ø 3,9 mm x 50 mm INOX A2-70

➤ **RC2/RC3 - POSIZIONAMENTO PROTEZIONI**  
**RC2/RC3 - PROTECTION POSITIONING**

**POSIZIONAMENTO SPESSORE DI PROTEZIONE CREMONESE**  
**GEARBOX SECURITY SPACER POSITIONING**

Avvitare in cava  
*Screw in the groove*

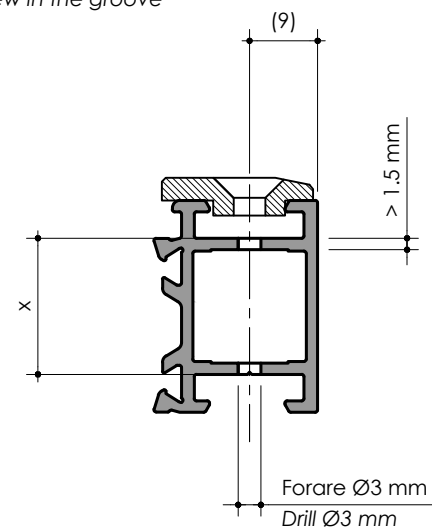

ISO 7050 Ø 3,9 mm x L = X + 10 mm INOX A2-70

**POSIZIONAMENTO SPESSORE DI PROTEZIONE CREMONESE**  
**GEARBOX SECURITY SPACER POSITIONING**

Avvitare in cava  
*Screw in the groove*

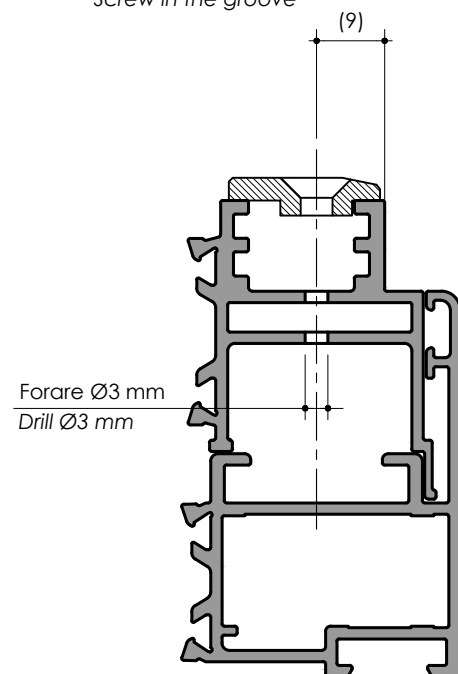

ISO 7050 Ø 3,9 mm x 30 mm INOX A2-70

**POSIZIONAMENTO PROTEZIONE CHIUSURA STULP**  
**STULP GEARBOX PROTECTION POSITIONING**

Avvitare in cava  
*Screw in the groove*

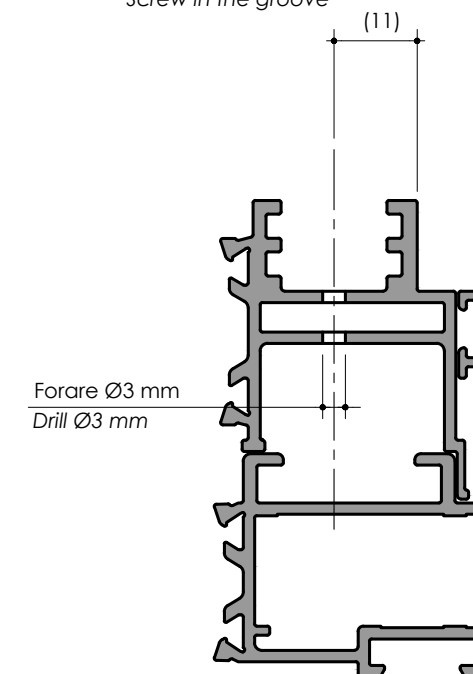

ISO 7050 Ø 3,9 mm x 30 mm INOX A2-70

➤ **INCOLLAGGIO STRUTTURALE VETRO**  
**GLASS PANEL STRUCTURAL GLUING**

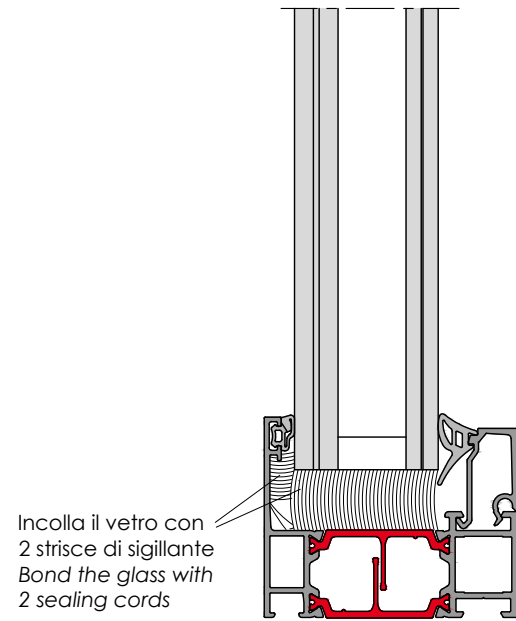

**Requisiti minimi di vetratura secondo la norma EN 356:1999**  
*Minimum glazing requirement according to EN 356:1999*

	<b>RC2</b>	<b>RC3</b>	
C67K	P4A	-	C67K
C77K	P4A	P5A	C77K
C77K - CS	-	P6B	C77K - CS
	Sikasil® WT-480  Sikasil® SG-500	Sikasil® SG-500	

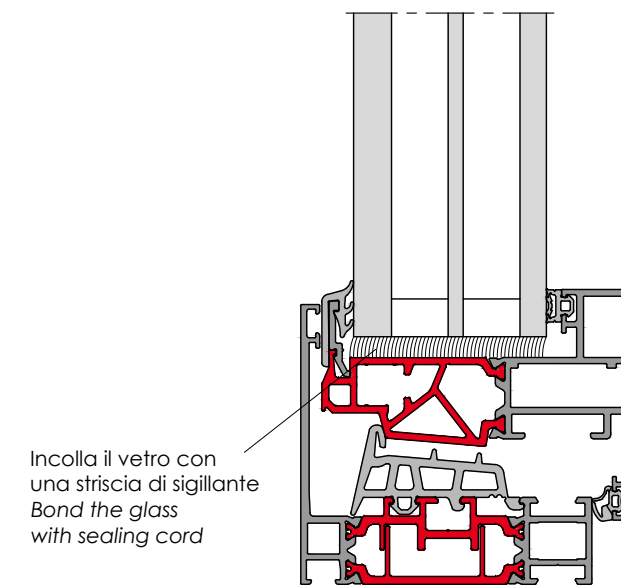
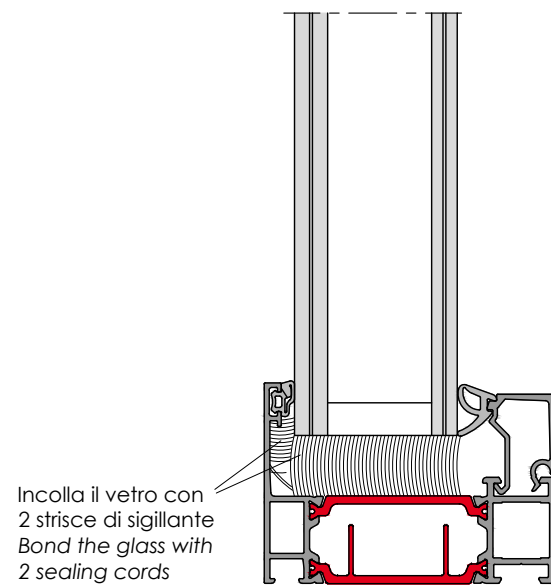
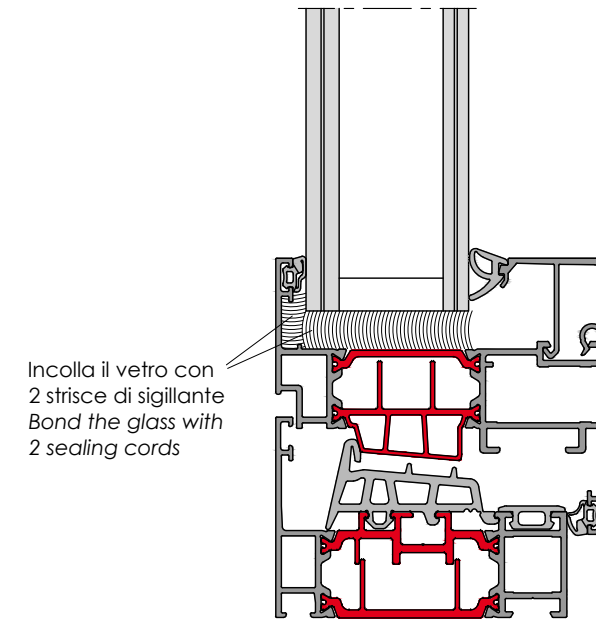

➤ RC2 - SCHEMA DI FISSAGGIO TELAIO  
RC2 - STRUCTURE FIXING DIAGRAM

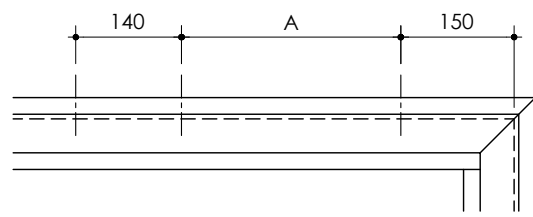
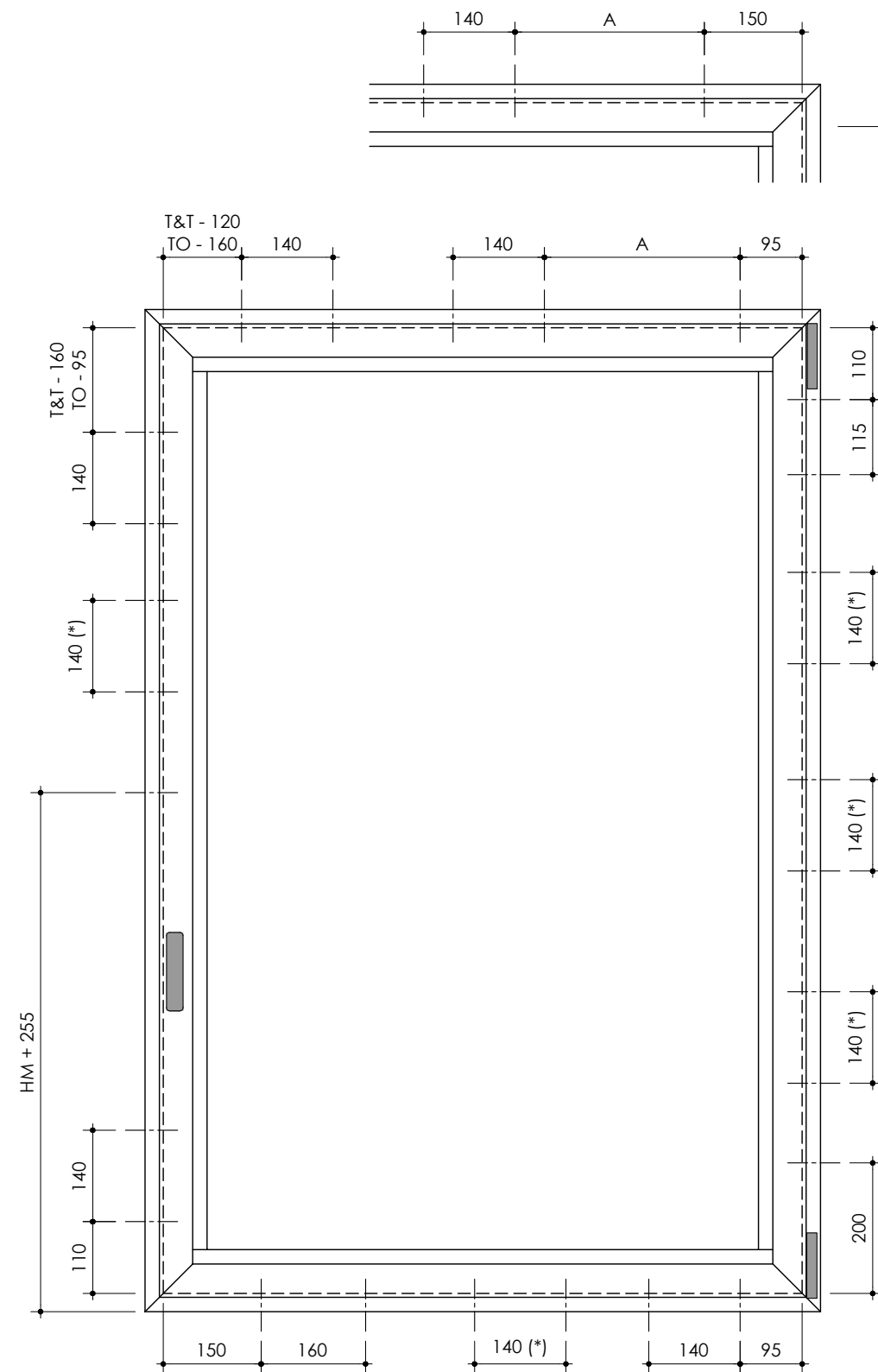

ISTRUZIONI DI FISSAGGIO PER CERNIERA NASCOSTA  
FIXING DIAGRAM FOR CONCEALED HINGE

	A
H48926	200
H48927 H48929	300
H48930 H48931	140
H48938 H48940 H48942 H48944	160
H48939 H48941 H48943 H48945	290

**ATTENZIONE**

APPLICARE DUE VITI PER OGNI INCONTRO.  
LA LUNGHEZZA E IL TIPO DI VITE DIPENDE DAL CONTROTELAIO O  
DAL TIPO DI MURATURA IN CUI È INSTALLATO IL TELAIO

**WARNING**

APPLY TWO SCREWS FOR EACH STRIKER  
THE LENGTH AND TYPE OF THE SCREWS MUST BE SUITABLE FOR THE  
COUNTERFRAME OR MASONRY WHERE THE FRAME IS INSTALLED

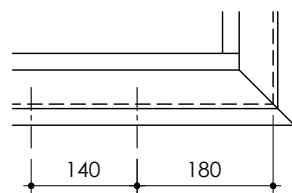
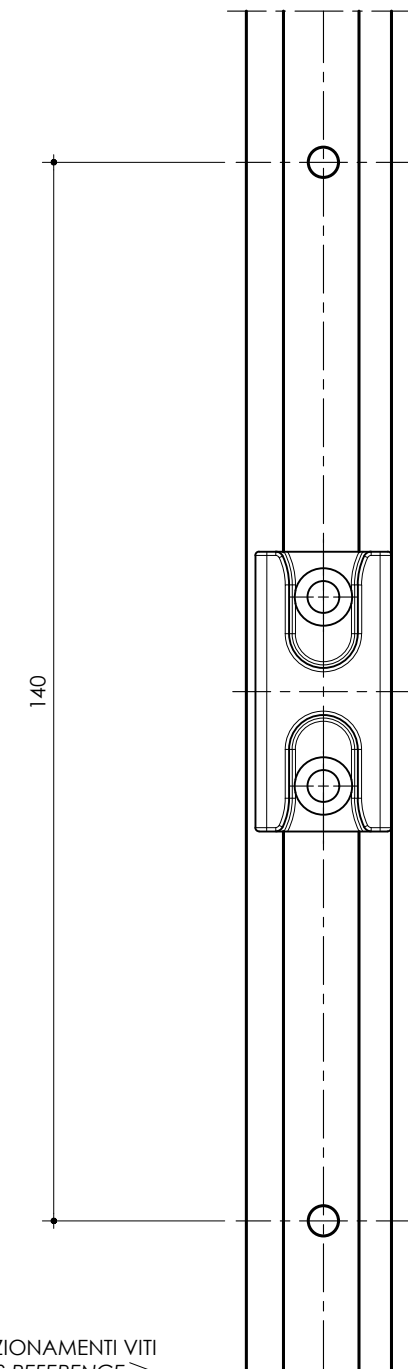

ISTRUZIONI DI FISSAGGIO PER CERNIERA NASCOSTA  
FIXING DIAGRAM FOR CONCEALED HINGE

RIFERIMENTO POSIZIONAMENTI VITI  
SCREWS POSITIONS REFERENCE

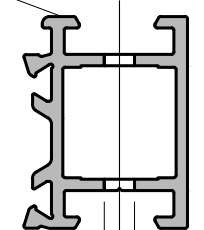

Forare Ø4 mm  
Drill Ø4 mm

**SPECIFICHE TECNICHE VITI**

Diametro viti  $D_{min}=4,8$  mm  
Certificazione obbligatoria per l'uso RC2

**SCREWS TECHNICAL SPECIFICATION**

Screws diameter  $D_{min}=4.8$ mm  
Mandatory certification for RC2 use

➤ RC2 - SCHEMA DI FISSAGGIO TELAIO  
RC2 - STRUCTURE FIXING DIAGRAM

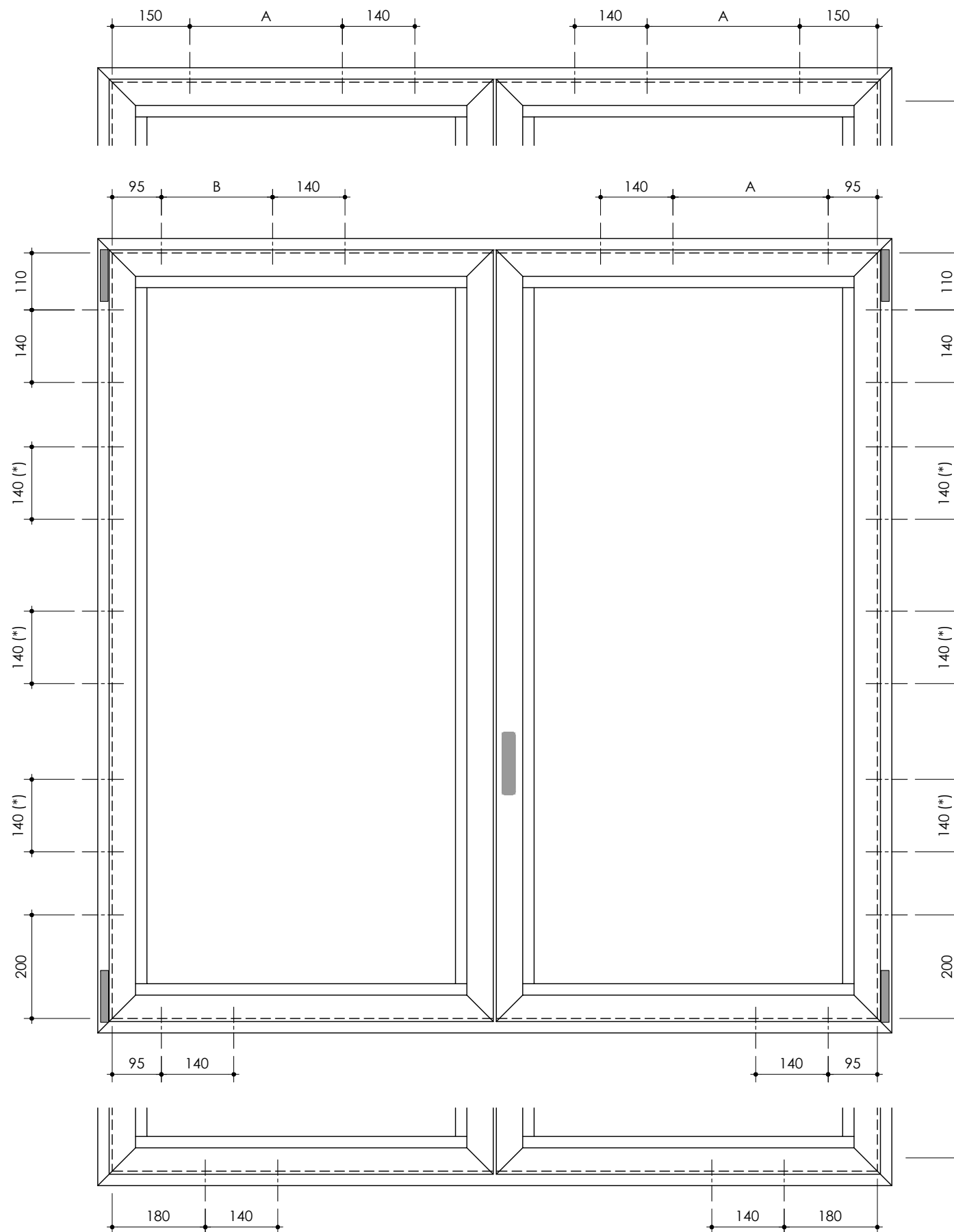

ISTRUZIONI DI FISSAGGIO PER CERNIERA NASCOSTA  
FIXING DIAGRAM FOR CONCEALED HINGE

	A	B
H48926	200	-
H48927 H48929	300	-
H48930 H48931	140	
H48938 H48940 H48942 H48944	160	
H48939 H48941 H48943 H48945	290	

**SPECIFICHE TECNICHE VITI**

Diametro viti  $D_{min}=4,8$  mm  
Certificazione obbligatoria per l'uso RC2

**SCREWS TECHNICAL SPECIFICATION**

Screws diameter  $D_{min}=4.8$ mm  
Mandatory certification for RC2 use

ISTRUZIONI DI FISSAGGIO PER CERNIERA NASCOSTA  
FIXING DIAGRAM FOR CONCEALED HINGE

➤ **RC3 - SCHEMA DI FISSAGGIO TELAIO**  
**RC3 - STRUCTURE FIXING DIAGRAM**

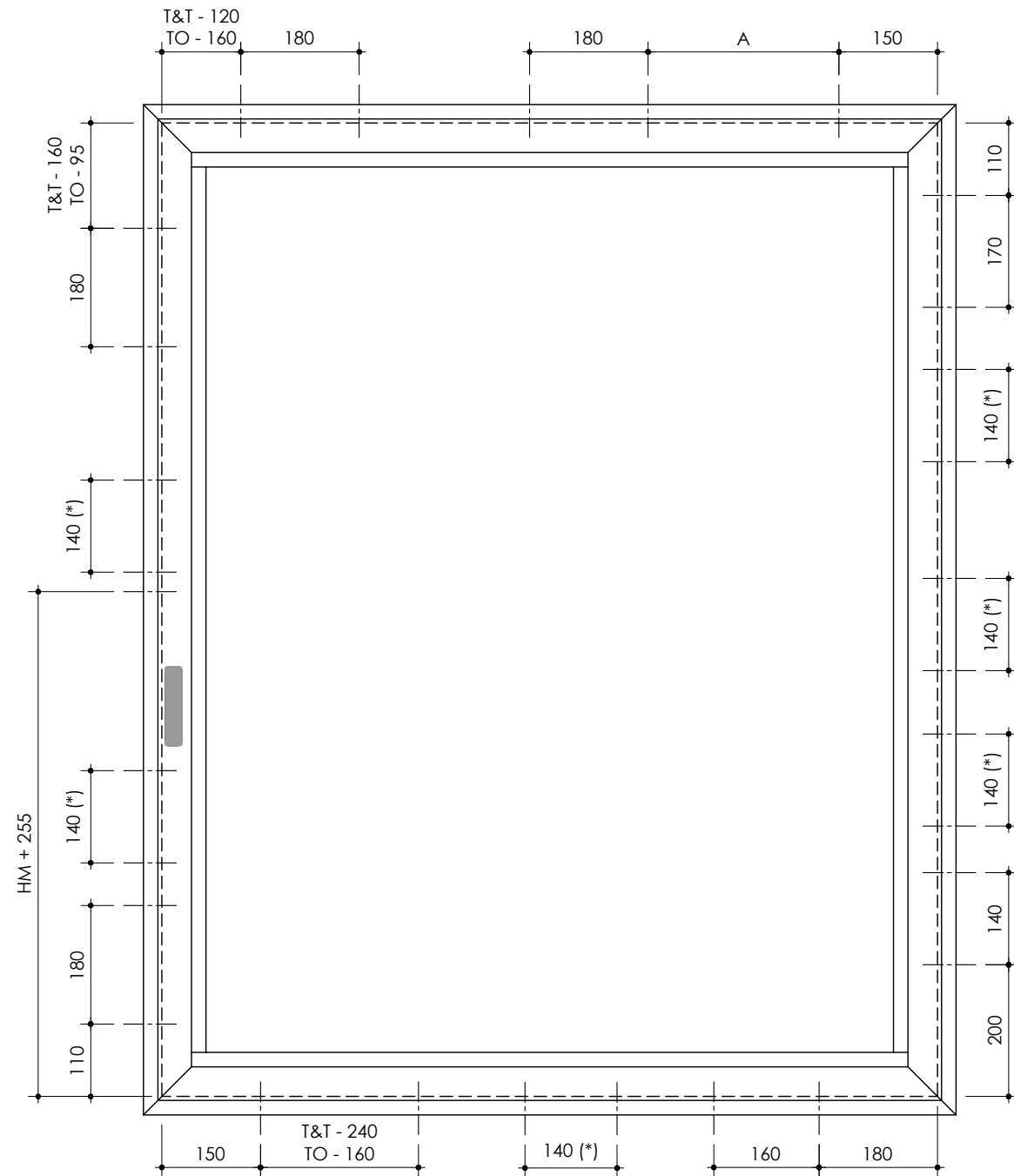

	A
H48938	160
H48940	
H48942	
H48944	
H48939	290
H48941	
H48943	
H48945	

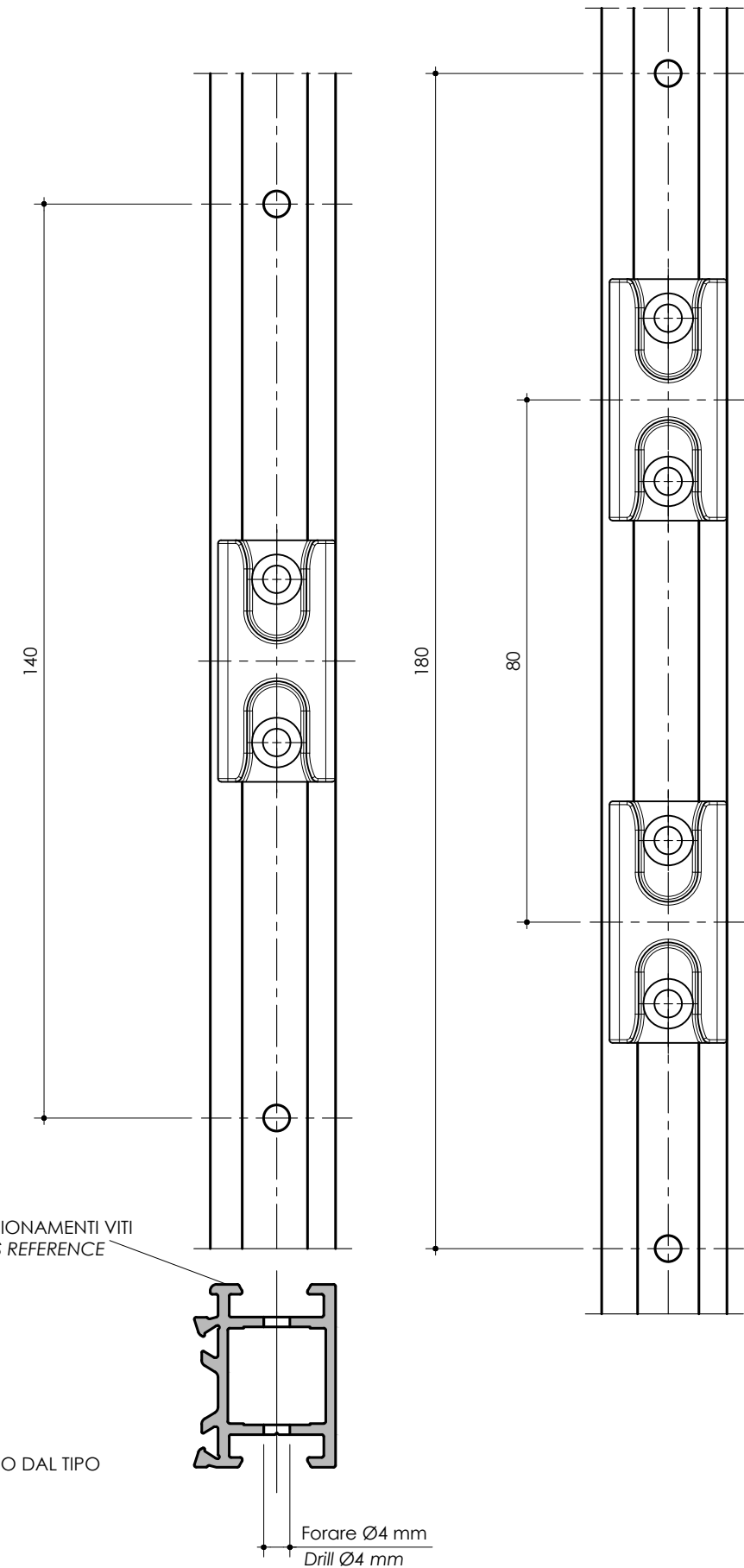

RIFERIMENTO POSIZIONAMENTI VITI  
 SCREWS POSITIONS REFERENCE

**SPECIFICHE TECNICHE VITI**

Diametro viti  $D_{min}=4,8$  mm  
 Certificazione obbligatoria per l'uso RC3

**SCREWS TECHNICAL SPECIFICATION**

Screws diameter  $D_{min}=4.8$ mm  
 Mandatory certification for RC3 use

**ATTENZIONE**

APPLICARE DUE VITI PER OGNI INCONTRO.  
 LA LUNGHEZZA E IL TIPO DI VITE DIPENDE DAL CONTROTELAIO O DAL TIPO  
 DI MURATURA IN CUI È INSTALLATO IL TELAIO

**WARNING**

APPLY TWO SCREWS FOR EACH STRIKER  
 THE LENGTH AND TYPE OF THE SCREWS MUST BE SUITABLE FOR THE  
 COUNTERFRAME OR MASONRY WHERE THE FRAME IS INSTALLED

➤ RC3 - SCHEMA DI FISSAGGIO TELAIO  
RC3 - STRUCTURE FIXING DIAGRAM

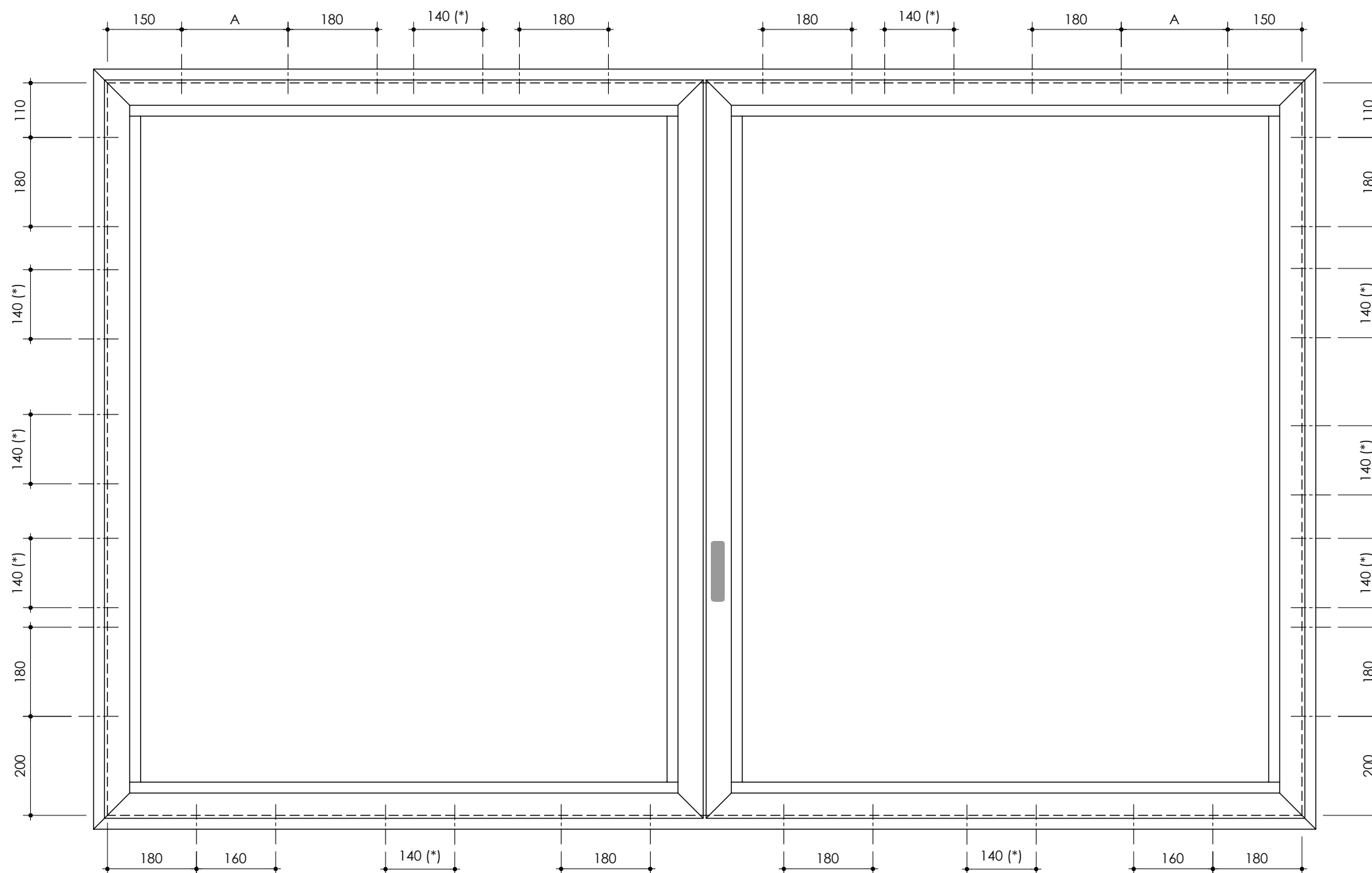

	A
H48938 H48940 H48942 H48944	160
H48939 H48941 H48943 H48945	290

**SPECIFICHE TECNICHE VITI**

Diametro viti  $D_{min}=4,8$  mm  
Certificazione obbligatoria per l'uso RC3

**SCREWS TECHNICAL SPECIFICATION**

Screws diameter  $D_{min}=4.8$ mm  
Mandatory certification for RC3 use



AluK (IT)

Via Monte Amiata, 3/a  
37057 - S. Giovanni Lupatoto  
Verona - ITALY

T:+39 045 9696611

[info.it@aluk.com](mailto:info.it@aluk.com)